

TYPE 21

POWERSTAT Variable Transformers of the 21-22 Series are of open construction and are primarily designed for back-of-panel mounting. The rated output for the type 21 Series is 5 amperes for constant current loads and 7 amperes for constant impedance loads. For the 22 Series, the rated output is 2.25 amperes for constant current loads and 3.25 amperes for constant impedance loads. The 21 Series types operate from 120 volt lines and the 22 Series types from 240 volt lines. The tapping arrangement permits an output voltage range of zero to line voltage or zero to 17 percent above line voltage. As shown in Figure A, 21-22 Series POWERSTAT Variable Transformers can be operated at any frequency between 50 and 2000 hertz without reduction in allowable output current. Figure B shows the regulation curves for operating at full rated load. The curves show the voltage drop at any brush setting when full load is applied. Voltage drops for loads less than full load are proportional. Driving torque, d-c resistance per coil and maximum core and brush loss when operating under no load are given in the chart. All manually

operated units have a 3 3/4 inch (95.3mm) dial graduated 0-100 and an angle of rotation of 320° from the zero to maximum output voltage. Adjustable shafts can be extended from either end of the units, permitting general utility mounting if desired. In addition to the conventional screw-type method of connection, terminal adapters supplied with the units can be quickly mounted on the terminals for use with push-on connectors or soldered connections.

Motor-driven units in the 21-22 Series are designated by a letter M prefix in the type number. When ordering, prefix the motor-driven type number with the desired motor speed in seconds. Example: 5M21-2.

CONNECTIONS AND RATINGS

TYPE	CONNECTION	INPUT		OUTPUT				KNOB ROTATION	TERMINALS						
		VOLTS	HERTZ	VOLTS	CONSTANT CURRENT LOAD		CONSTANT IMPEDANCE LOAD		KNOB ON BASE END			KNOB ON RADIATOR END			
					MAX. AMPS.	MAX. KVA	MAX. AMPS.		MAX. KVA	INPUT	JUMPER*	OUTPUT	INPUT	JUMPER*	OUTPUT
21 M21§	#1 Single Phase	120	50/60	0-120	5	0.60	7	0.84	CW	1-4	—	3-4	1-4	—	1-3
				0-140	5	0.70	—	—	CCW	1-4	—	1-3	1-4	—	3-4
				0-120	5	1	7	1.5	CW	4-5	—	3-4	1-2	—	1-3
									CCW	1-2	—	1-3	4-5	—	3-4
22 M22§	#1 Single Phase	240	50/60	0-240	2.25	0.54	3.25	0.78	CW	1-4	—	3-4	1-4	—	1-3
				0-280	2.25	0.63	—	—	CCW	1-4	—	1-3	1-4	—	3-4
				0-240	2.25	0.63	—	—	CW	4-5	—	3-4	1-2	—	1-3
									CCW	1-2	—	1-3	4-5	—	3-4
21-2 M21-2§	#2 1-Phase Series	240	50/60	0-240	5	1.2	7	1.7	CW	1-1	4-4	3-3	4-4	1-1	3-3
				0-280	5	1.4	—	—	CCW	4-4	1-1	3-3	1-1	4-4	3-3
	#2 3-Phase Open Delta	120	50/60	0-120	5	1	7	1.5	CW	5-5	4-4	3-3	2-2	1-1	3-3
				0-140	5	1.2	—	—	CCW	2-2	1-1	3-3	5-5	4-4	3-3
				0-120	5	1	7	1.5	CW	1-4-1	4-4	3-4-3	4-1-4	1-1	3-1-3
									CCW	4-1-4	1-1	3-1-3	1-4-1	4-4	3-4-3
22-2 M22-2§	#2 1-Phase Series	480	50/60	0-480	2.25	1.1	3.25	1.6	CW	1-1	4-4	3-3	4-4	1-1	3-3
				0-560	2.25	1.3	—	—	CCW	4-4	1-1	3-3	1-1	4-4	3-3
	#2 3-Phase Open Delta	240	50/60	0-240	2.25	0.94	3.25	1.4	CW	5 5	4-4	3-3	2-2	1-1	3-3
				0-280	2.25	1.1	—	—	CCW	2-2	1-1	3-3	5-5	4-4	3-3
0-240				2.25	0.94	3.25	1.4	CW	1-4-1	4-4	3-4-3	4-1-4	1-1	3-1-3	
								CCW	4-1-4	1-1	3-1-3	1-4-1	4-4	3-4-3	
21-3 M21-3§	#3 3-Phase Wye	240	50/60	0-240	5	2.1	7	2.9	CW	1-1-1	4-4-4	3-3-3	4-4-4	1-1-1	3-3-3
				0-280	5	2.4	—	—	CCW	4-4-4	1-1-1	3-3-3	1-1-1	4-4-4	3-3-3
			60	0-280	5	2.4	—	—	CW	5-5-5	4-4-4	3-3-3	2-2-2	1-1-1	3-3-3
									CCW	2-2-2	1-1-1	3-3-3	5-5-5	4-4-4	3-3-3
22-3 M22-3§	#3 3-Phase Wye	480	50/60	0-480	2.25	1.9	3.25	2.7	CW	1-1-1	4-4-4	3-3-3	4-4-4	1-1-1	3-3-3
				0-560	2.25	2.2	—	—	CCW	4-4-4	1-1-1	3-3-3	1-1-1	4-4-4	3-3-3
			60	0-560	2.25	2.2	—	—	CW	5-5-5	4-4-4	3-3-3	2-2-2	1-1-1	3-3-3
									CCW	2-2-2	1-1-1	3-3-3	5-5-5	4-4-4	3-3-3

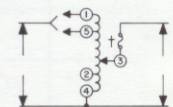

CONNECTION 1

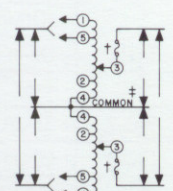

CONNECTION 2

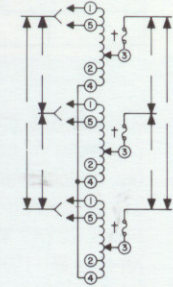

CONNECTION 3

CONNECTIONS SHOWN ARE FOR CW KNOB ROTATION, KNOB ON BASE END (CCW ROTATION, KNOB ON RADIATOR END)

‡Common used as third leg in 3-phase open delta or neutral in 3-wire single phase series and 4-wire 3-phase wye connections; not used in 2-wire series or 3-wire wye connections.

*Jumper provided in standard common position should be moved or removed as required.

§Motor-driven types use connections for CW rotation, knob on radiator end.

†Fuse recommended, not supplied.



MOTOR-DRIVEN TYPES

TYPE	Approximate Driving Torque Oz-In	KpCm	No-Load Loss at 60 Hertz† (Watts)	D-C Resistance per Coil*† (Ohms)
21	15-25	1.1-1.8	3.0	4.4
21-2	35-45	2.5-3.2	6.0	4.4
21-3	70-80	5-5.8	9.0	4.4
22	20-30	1.4-2.2	3.0	10.8
22-2	45-60	3.2-4.3	6.0	10.8
22-3	70-90	5-6.5	9.0	10.8

†Data applies to M prefixed models also.
*Measured from start to end of winding.

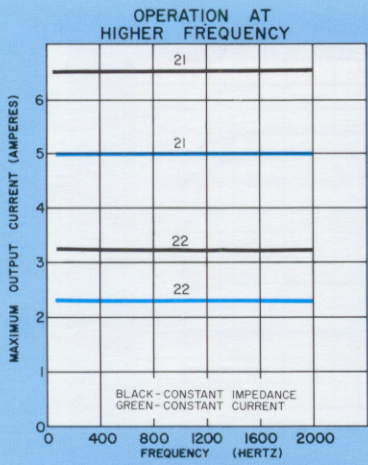
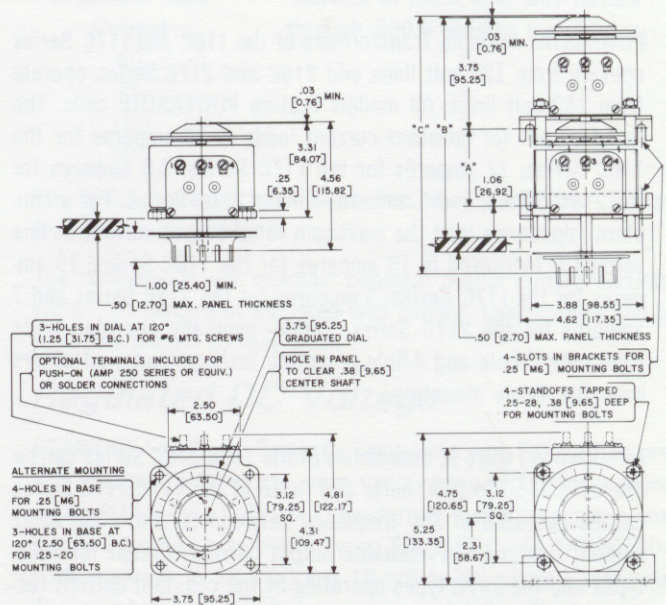

FIGURE A

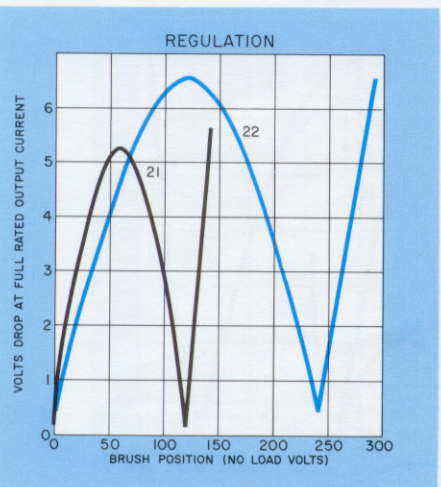
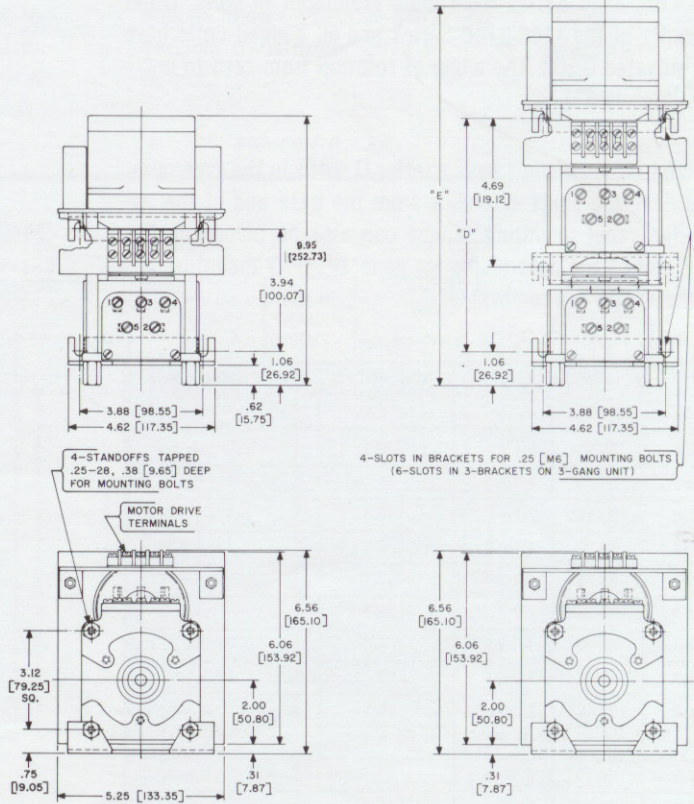

FIGURE B

SINGLE MANUAL

GANGED MANUAL

TYPE	"A"	"B"	"C"	"D"	"E"
2-GANG	2.69 [68.32]	7.50 [190.50]	8.75 [222.25]	7.38 [187.45]	13.39 [340.11]
3-GANG	6.12 [155.45]	10.94 [277.87]	12.19 [309.63]	10.81 [274.57]	16.83 [427.48]



SINGLE MOTOR DRIVEN

GANGED MOTOR DRIVEN