

AC Watt / Var Transducer

SPWK301

- ⊙ Standard output with 0 to 1 mA_{dc}
- ⊙ Accuracy of reading base 0.25% reading + 0.02% ro
- ⊙ Dual isolated output watt / var eliminating ground loops effect
- ⊙ High magnetic field immunity
- ⊙ Meets IEEE SWC test

MODEL...SPWK

301 - 3 phase 4 wires / 3 elements

Description

HC model SPWK watt / var transducer is compact, designed to be a very accurate mode with DC 1mA output directly proportional to an AC rated input. output of watt & var are isolated each other to eliminate ground effect. For utility, the unit are useful including industry, laboratories & process control requiring accurate power or energy measurements.

Specification

1.Accuracy 0.25% RD + 0.02%RO / 23 ± 3°C

2.Input (each element)

Range	Effective voltage 85-150V; Current 0-6A Nominal voltage 120V current 5A
Over capability	Voltage 200V continuous ; 250V ... 10sec / hour; 500V ... 2sec / hour Current 15A continuous ; 50A ... 10sec / hour; 250A...1sec / hour ; 400A ... 0.5sec / hour
Burden	Voltage < 0.1VA at 120V input; Current < 0.2VA at 5A input
Frequency	Watt 57-63Hz; Var 60Hz only
Protection	Full protection for SURGE, EMI & RFI

3.Output (isolated with input)

	Dual outputs watt & var isolated each other (600 Vdc)
Range	Standard DC 0 to ±1mA; option ± (0 - 1 / 0 - 5 / 0 - 10) Vdc DC 0 to ±1mA calibration vs 0 to ± 1500W / ± 1500Var ... 3ø4W / 3 elements
Output load	Maximum 10K ohm for 0 to ±1mA output
Output impedance	> 30 Mega ohm
Response time	< 400 ms from 0 to 99% RO at operating
Ripple	< 0.5% P-P RO
Long term stability	< 0.1% RO per year (typically)
Temperature stability	< 0.01% per degree C, from 0 to 55°C
Adjustment	Span ± 5% / 10%; zero ± 2.5% / 5% on request
Protection	No damage ... open or short; full protection ... SURGE, EMI, RFI
Magnetic effecton	< 0.04% at center 400 A-T / M

4.Power supply AC115 ± 20%, 50-70Hz, < 3VA

5.Operation condition

Environment

Temperature	-5 to 60°C
Humidity	20 to 99% RH non condensed
Elevation	Under 3000 meters
Magnetic field	500 A-T / M
Waveform	Watt - fundamental with 20% 3rd harmonics Var - sinusoidal
Power factor	Any
Dielectric strength	4KV AC rms 1 minute between input / output / power / case IEC 688
Impulse test	ANSI C37.90/1989, IEEE 587/1983, IEC 255-3, 6KV (1.2 x 50 us), 3KA (8 x 20 us) current only
Surge test (ring wave)	IEEE587/1983 (3KV - 0.5us / 100KHz) IEC 255-3 (2.5KV - 0.25ms / 1MHz)

Terminal Connection

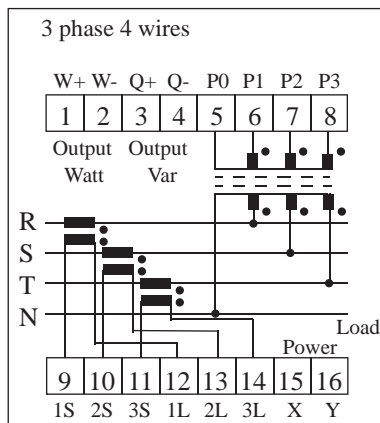

Dimension

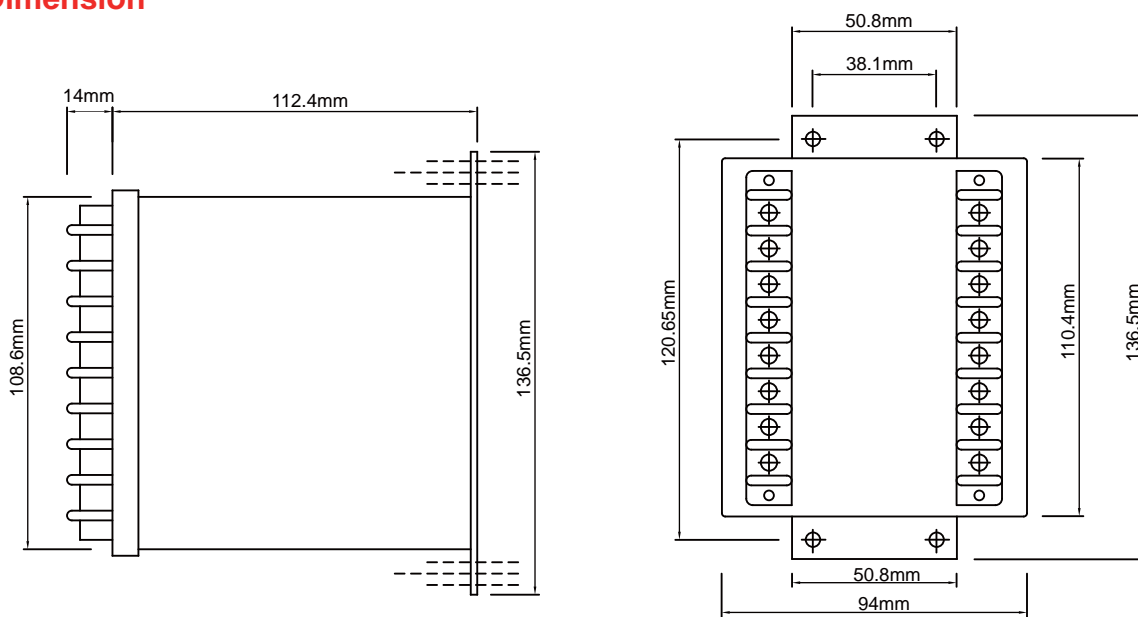

HSIANG CHENG ELECTRIC CORP.

4F., No.11, Ln. 235, Baoqiao Rd., Xindian Dist., New Taipei City 231, Taiwan

TEL : 886-2-2917-5865~9

E-mail : expo.sales@hc.com.tw

FAX : 886-2-2917-3946

http://www.hc.com.tw