

# Digital Setting Meter Relay

**SME**

## Description

Model SM series are a Potentiometer setting meter relays with dual Hi & Lo setting. The setters are used multi-turns resistive potentiometers as preset buffers which setting able to be read directly in display for switch selection. The input functions of the units are of wide varieties & ranges, including many parameters of industry process and power system as DCV, ACV, DCA, ACA, DC rate, temperature as standard products. For wide application, with some external transducers, the series can be extended to a wider field application as watt, var, power factor & etc.

The unit provides four digits display up to 9999 counts with fine resolution & the displays are of high rate-super brightness LED, 0.56" size.

Dual control outputs compliant Hi & Lo setting of SPDT relay contacts of an on-off control type. The outputs also comply delaying function adjusted 0-30 seconds standardly & longer requirement for 0-60 or 0-120 secs based on specified request. Dead band also an option available is selectively & alternatively to time delayer.

Special design in meter front of an open-door type, it keeps convenience in presetting & protects setting to avoid undesired misschange in field application.

## Features

- ⊙ Multi-turns Potentiometer setting
- ⊙ Dual Hi & Lo setting
- ⊙ Wide input parameters & ranges
- ⊙ Output with adjustable time delayer
- ⊙ 4 digits up to 9999 counts

## Specification

<b>Accuracy</b>	0.1% fs ± 2 counts
<b>Stability</b>	Temperature < 100 ppm per °C, 5-50°C Long term stability < 0.15% drift per year
<b>Input burden</b>	≥ 1 Megaohms ≤ 500 mV drop
<b>Display</b>	4 digits maximum 9999 counts, 0.56" super rate LED
<b>Setting</b>	(1) Hi & Lo set standard, Hi-Hi set optional (2) Hi comparator setting < meter input output relay energied (3) Lo comparator setting > meter input output relay energied (4) multi-turns potentiometer for each setting (5) switchable display range for S1, S2 & M (input measured)
<b>Response time</b>	Analog conversion < 1 sec of average integration typically Analog to Digital conversion 2 sample rate per second
<b>Input over capability</b>	Voltage maximum for 100V rms or 2 x full input which ever great current input 2 times continuous, 10 times 2 sec., 25 times 0.5 sec.
<b>Control output</b>	(1) on-off control type (2) relay contact output of spdt type for each setting (3) capacity AC250V / 2A, AC125V / 3A, DC24V / 3A (4) time delayer adjustable 0-30 sec. typically, 0-60, 0-120 sec. for option (5) dead band for option alternatively & available to time delayer (6) output indication : led lamp energied in front panel
<b>Comm. mode voltage</b>	2KV rms 50/60 Hz 1 minute
<b>Impulse voltage</b>	4KV 1.2 x 50 us common mode test
<b>Operation condition</b>	Temperature 0-50°C, 20-90% RH non-condensed
<b>Storage condition</b>	Temperature -10~70°C
<b>Power supply</b>	Standard AC 110/220V 50 / 60HZ ± 15%, < 5VA Option DC 12V / 24V / 48V / 125V, < 6 Watts

# Order information

## Order form of DC Process Rate

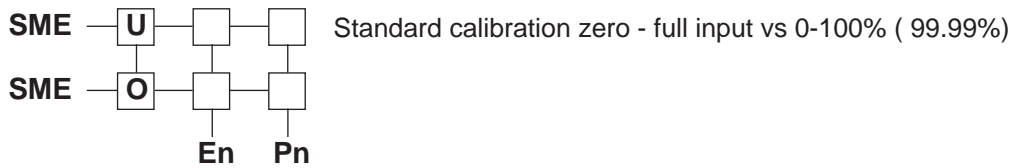

Input voltage range	En	Input current range	En	Auxiliary power	Pn
0 - 10 mV	11	0 - 1 mA	1	AC110V/220V	S
0 - 100 mV	12	0 - 5 mA	2	DC12V	1
0 - 1 V	13	0 - 10 mA	3	DC24V	2
0 - 5 V	14	0 - 20 mA	4	DC48V	3
1 - 5 V	15	4 - 20 mA	5	DC125V	4
0 - 10 V	16	0 - 50 mA	6		
2 - 10 V	17	10 - 50 mA	7		
custom specified	Y				

## Operation

### Setting function

Function	Measured status	Output status	Lead indicator
Hi - set	The measured input > setting	Controlled output relay energied	S1 on
Lo - set	The measured input < setting	Controlled output relay energied	S2 on

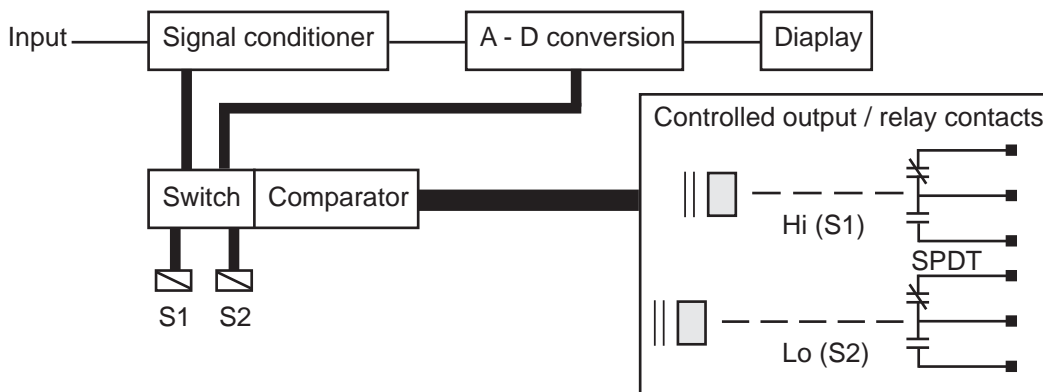

## Terminal connection

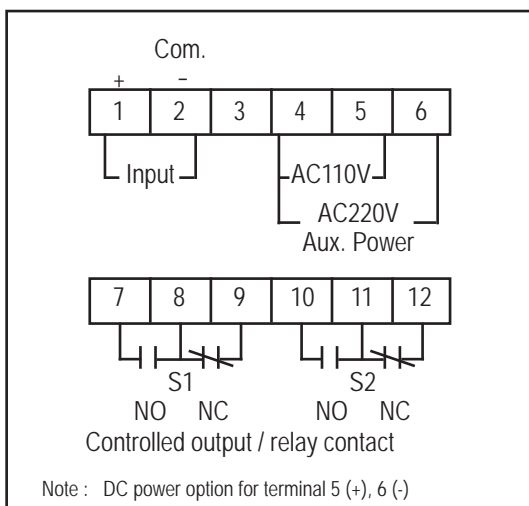

## Dimension

