



Model HST-90U

Analog Panel Meters



HST-90U 3.5"

Features

Case and Composition	Polycarbonate front and Polybutylene Terephthalate(PBT). Three or Four studs mounting.
Accuracy	AC Class 2.5 DC Class 2.0 Rectifier class 2.0
Color Pointer	Black case and white scale plate. Sword type color in black.
Hz Meter :	
Measuring Ranges :	45~56 Hz, 45~55 Hz, 55~65 Hz
Rated Voltage :	110V, 220V
Accuracy :	Class 2.0

Measuring Ranges

Moving Coil Type

DC μ A	DCmA	DC A	DC mV	DC V
50	1 200	1	50	3 200
100	2 250	1.5	60	5 300
150	5 300	10	100	10 500
200	10 500	20	500	20 600
250	20 800	30		30
300	50			50
500	100			100
800	150			150

Moving Iron Type

AC mA	AC A	AC V
50	1	150
100	5	250
150	10	300
200	15	500
250	20	600
300	30	
500	50	
800		

Rectifier Type

AC V
30
50
100
150
200
300
500
600

HZ Meter

HZ
45-56
45-55
55-65

Dimensions

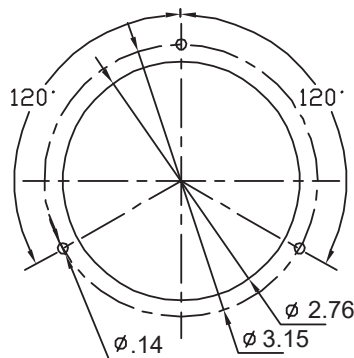

PANEL CUT-OUT

