

EV300

Power & Energy Panel Meters Datasheet

ACCUENERGY



DESCRIPTION

The EV300 Series power and energy panel meter is an affordable, user-friendly three-phase metering solution for monitoring power, voltage, current, and bi-directional energy. Certified to utility revenue grade accuracy standards, its standard panel mount design, Modbus-RTU communications, and array of I/O and alarm options make this economical meter a valuable tool in any industrial or commercial environment.

FEATURES

- + Utility Revenue Grade: ANSI C12.20 0.5 Class & IEC 62053-22 0.5s Class
- + Communicate via Modbus-RTU through the built-in RS485 port
- + Pulse, analogue transducer, & alarm-triggered output options available
- + Field-configurable 5A or 1A CT input
- + Two form factors: Standard panel mount meter or built into an AcuPanel pre-wired enclosure

KEY FEATURES

Revenue Grade Certification

- + Ideal for applications that require exceptional accuracy, the EV300 meets utility revenue grade accuracy standards across 50Hz and 60Hz systems. Certified for ANSI C12.20 Class 0.5 and IEC 62053-22 Class 0.5s, it takes true RMS measurements to deliver superior results.

Bi-Directional Energy Metering

- + Critical in renewable energy applications, such as solar or wind, the EV300 can measure the flow of energy in two directions in order to capture both consumption and generation.

Multiple I/O Options

- + With a variety of I/O combinations to choose from, the EV300 can be configured to monitor switches, deliver energy information to a data acquisition server, interface with a PLC, or trigger critical alarms.
- + Digital Input: Monitor switch status
- + Digital Output: Sent energy data to a data acquisition server
- + Analogue Output: 4-20mA transducer type output
- + Relay Output: Over/under limit triggered tripping relay to control load on/off

Standard Modbus-RTU Communications

- + The EV300 includes a built-in RS485 port for communicating over Modbus-RTU in industrial environments. Daisy-chain multiple meters together for efficient data collection.

Built-In Power Supply

- + 24Vdc provides direct power supply to digital input. Reduce the cost, complication, and space of installing an additional low voltage power supply in the panel.

Voltage

- + Supports any voltage system with a rating between 10V to 230V/400V and can be used with or without a potential transformer.

Current

- + The field-configurable 5A and 1A CT input will suit any industrial current transformer.

Frequency

- + Worldwide compliance: The automatic frequency detection feature adapts to 50Hz or 60Hz systems without sacrificing accuracy.



APPLICATIONS

- + Building Automation and Control Systems
- + Energy Management Systems
- + Industrial Facility Metering
- + Commercial Buildings
- + Tenant Submetering

SPECIFICATIONS

Metering

PARAMETERS	ACCURACY	RESOLUTION	RANGE
Voltage	0.5%	0.1V	10V~500kV
Current	0.5%	0.001A	0~99990A
Power	0.5%	1W	-9999MW~9999MW
Reactive Power	0.5%	1var	-9999Mvar~9999Mvar
Apparent Power	0.5%	1VA	0~9999MVA
Power Factor	0.5%	0.001	-1.000~1.000
Frequency	0.2%	0.01Hz	45~65Hz
Energy	0.5%	0.1kWh	0~99999999.9kWh
Reactive Energy	0.5%	0.1kvarh	0~99999999.9kvarh
Temperature Coefficient	<100 ppm/°C (0~50°C)		

Input

CURRENT INPUTS (Each Channel)

Nominal Current Options	5A/1A
Metering Range	0~6A / 0~2A
Pickup Current	5mA / 1mA
Withstand	20Arms continuous 100Arms for 1 second, non-recurring
Burden	0.05VA (Typical) @ 5Arms
Accuracy	0.5% Full Scale

VOLTAGE INPUTS (Each Channel)

Nominal Full Scale	230Vac L-N, 400Vac L-L (+20%)
Withstand	1500Vac Continuous 2500Vac, 50/60Hz for 1 Minute
Input Impedance	2MΩ per Phase
Metering Frequency	45Hz~65Hz
Pickup Voltage	10Vac
Accuracy	0.5% Full Scale

ENERGY ACCURACY

Active	Class 0.5s (According to IEC 62053-22) Class 0.5 (According to ANSI C12.20)
Reactive	Class 2 (According to IEC 62053-23)

Communications

RS-485

Half-duplex, Optically Isolated
1200 to 57600bps

PROTOCOLS

Modbus-RTU

Control Power

Universal

AC/DC CONTROL POWER

Operating Range	100~240Vac, 50/60Hz; 100~300Vdc
Burden	2W
Frequency	50/60Hz
Withstand	2500Vac, 50/60Hz for 1 minute
Installation Category III (Distribution)	

I/O Options

DIGITAL INPUT (Switch Status)

Optical Isolated Voltage	2500Vac RMS
Input Type	Wet
Input Resistance	4kΩ (Typical)
Input Voltage Range	16~30Vdc
Input Current (Max)	7.5mA

DIGITAL OUTPUT (DO) (Photo-MOS)

Voltage Range	0~250Vac/dc
Load Current	100mA (Max)
Output Frequency	25Hz, 50% Duty Ratio (20ms ON, 20ms OFF)
Isolation Voltage	2500Vac

RELAY OUTPUT (RO)

Switching Voltage (Max)	250Vac, 30Vdc
Load Current	5A(R), 2A(L)
Set Time	10ms (Max)
Contact Resistance	30mΩ (Max)
Isolation Voltage	2500Vac
Mechanical Life	1.5×10 ⁷

ALARM OUTPUT

Alarm Parameters	V1, V2, V3, V12, V23, V31, I1, I2, I3, Vavg, Vlavg, lavg, In, P, Q, S, F and PF
Output Type	RO/DO

ANALOGUE OUTPUT (AO)

Output Range	4~20mA/0~20mA
Resolution	12-bit
Output Capability	Max Load: 750Ω
Accuracy	0.50%
Temperature Drift	50ppm/°C Typical
Isolation Voltage	500Vdc
Open Circuit Voltage	15V

POWER SUPPLY FOR DI (24 Vdc)

Output Voltage	24Vdc
Output Current	42mA
Load (Max)	6 DIs

SPECIFICATIONS

Operating Environment		Standard Compliance & Certifications	
Operating Temperature	-25°C to 70°C -13°F to 158°F	Measurement Standard	IEC 61036 Class1, ANSI C12.16 Class10
Storage Temperature	-40°C to 85°C -40°F to 176°F	Environmental Standard	IEC 60068-2
Relative Humidity	5% to 95% Non-Condensing	Safety Standard	IEC 61010
Pollution Degree	2	EMC Standard	IEC 61000-4/2-3-4-5-6-8-11
		Outlines Standard	DIN 43700

FUNCTION LIST

● Function; ⊙ Option; Blank NA

	Function	Parameters		EV387	EV390
Metering	Voltage	V	V	●	●
	Current	I	A	●	●
	Power	P	kW		●
	Reactive Power	Q	kvar		●
	Apparent Power	S	kVA		●
	Power Factor	PF			●
	Frequency	F	Hz		●
Energy	Energy	Ep_total, Ep+, Ep-	kWh	●	●
	Reactive Energy	Eq_Total, Eq+,Eq-	kvarh	●	●
DI Option	Digital Input	2DI		●	●
		4DI		⊙	⊙
RO/DO Option either/or	Relay Output	2RO		⊙	⊙
	Digital Output	2DO		⊙	⊙
AO/PO Option either/or	Analogue Output	4~20mA		⊙	⊙
	Auxiliary Power	24Vdc		⊙	⊙
Communications	RS485, Modbus-RTU protocol			●	●
Display	LCD Display			●	●
Dimensions	96×96×73mm (Cut Out: 92×92mm)				

I/O SELECTION TABLE

Model	E0 (Base Meter)	E1	E2	E3	E4
Digital Input	2	6	6	6	6
Digital Output (Pulse)	-	-	2	2	-
Analogue Output (4-20mA)	-	-	-	2	2
Relay Output	-	2	-	-	2
Power Supply for DI	-	1	1	-	-

WIRING DIAGRAMS

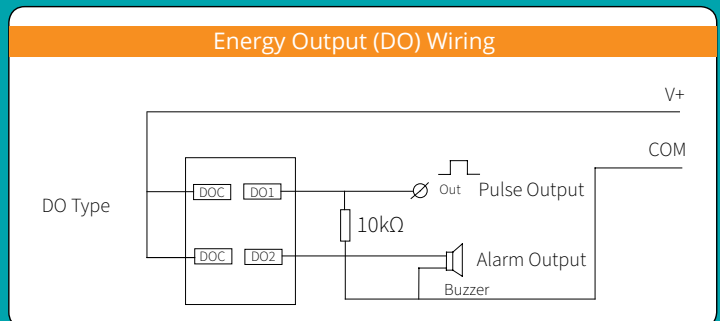
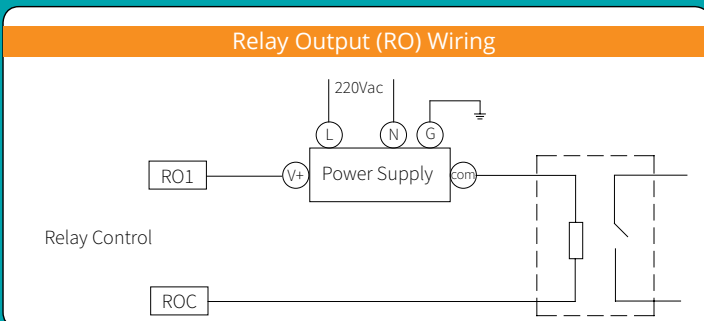
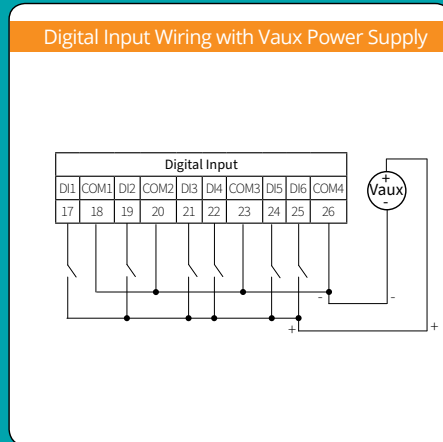
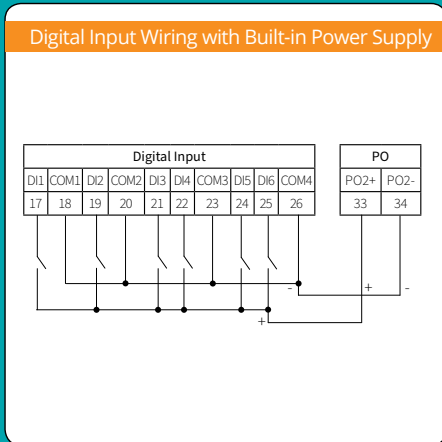
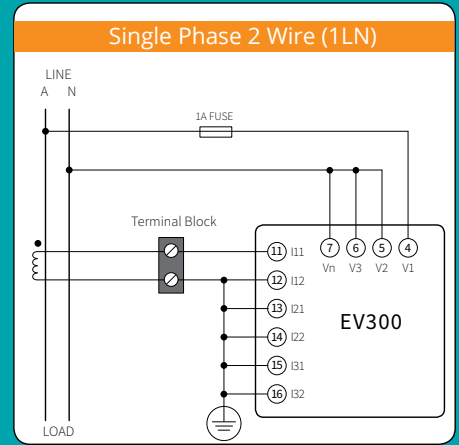
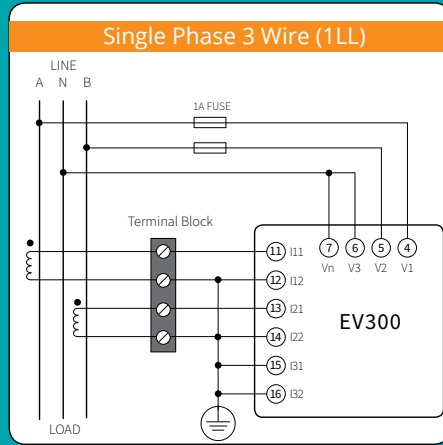
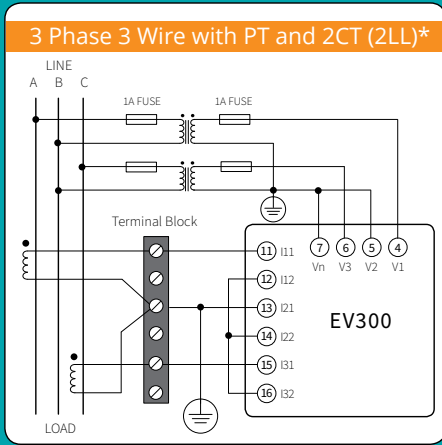
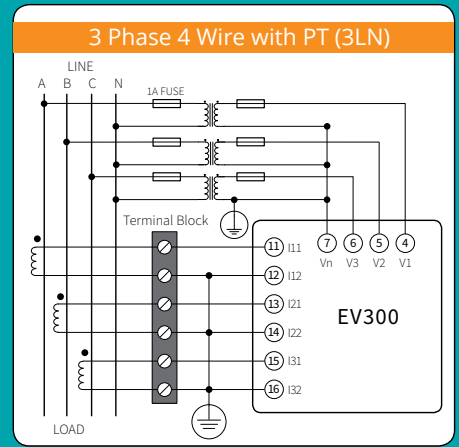
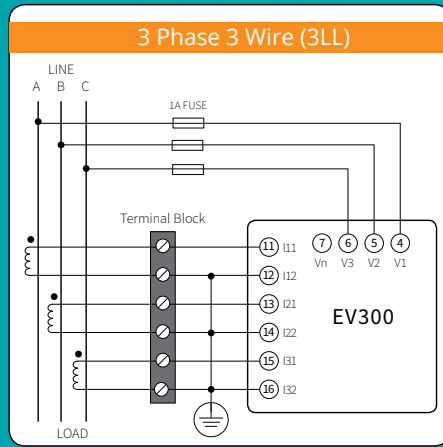
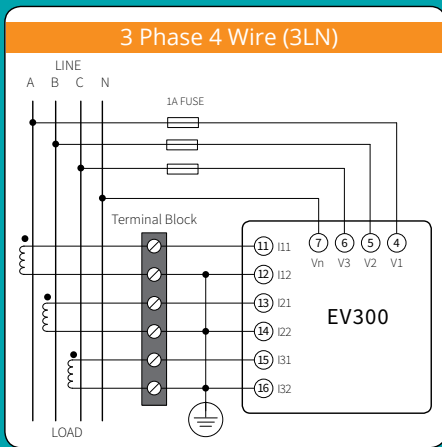

*Note: 2CT configuration is optional only in 3 Phase 3 Wire system.

DIMENSIONS

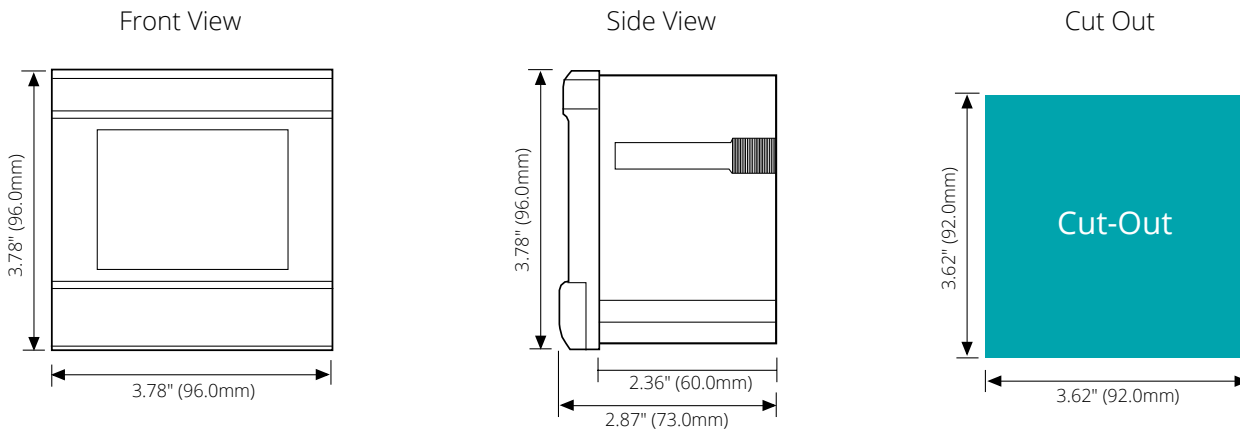

ACCESSORIES

Protective Display Cover

The Protective Display Cover is designed for Acuvim II Series energy meters and other 96mm by 96mm display panel meters. Crucial in harsh environments, it increases the IP environmental rating of a meter's display to IP66 or NEMA 4X.



USB RS485 Converter

This plug-and-play USB to Serial RS485 Converter is designed to provide a convenient, reliable USB connection to the Acuvim II Series power meters and other serial devices.



ORDERING INFORMATION

Model	IO Option
EV387	E0: 2DI
EV390	E1: 6DI+2RO+PS
	E2: 6DI+2DO+PS
	E3: 6DI+2DO+2AO
	E4: 6DI+2RO+2AO
Ordering Example:	EV387 - E1
	EV390 - E3

Accessories (Optional)	
96-IP66	Screen Protector for 96 x 96mm meters
USB-RS485	RS485 to USB converter for connecting meter with computer, maximum distance 1200 meters.
Ordering Example:	USB-RS485



Accuenergy (Canada) Inc.
 Los Angeles - Toronto - Beijing - Pretoria
 North America Toll Free: 1-877-721-8908
 Web: www.accuenergy.com
 Email: marketing@accuenergy.com

Revision Date: Apr 2023 Version: 1.0.2
 Specs Subject To Change Without Notice.



ISO9001 Certified