

General Specifications

Model UP150 Program Temperature Controller



GS 05C01F12-01E

General

The UP150 program temperature controller has one program pattern consisting of 16 segments, and it can easily be set and operated.

The two event outputs are provided as standard, and the external contact input, communication and retransmission output as options.

The universal input selectable an input type among TC, RTD and Voltage, and the three types of outputs are also provided.

The front panel has a splash-proof and dust-proof design (IP65), which enables the use in the dusty environment.

UP150



Model and Suffix Codes

Model	Suffix code	Description
UP150		Program Temperature Controller
Control output	-R	Relay output (time-proportional PID or on/off control)
	-V	Voltage pulse output (time-proportional PID)
	-A	4 to 20mA output (continuous PID)
Fixed code	N	Always N
Option	/EX	RUN/RESET switching, and HOLD program /cancel HOLD program switching by external contacts (Note1)
	/RET	PV retransmission output in 4 to 20mA
	/RS	Communication function (MODBUS, PC-Link, Ladder) (Note1) (Note2)
	/V24	Power Supply 24V DC / 24V AC

Note1: /RS option and /EX option cannot be specified at the same time.
 Note2: When specifying the /RS option, be sure to order the required number of copies of Communication Functions User's Manual separately.

Check the package contents against the list below.

- Program temperature controller 1
- Mounting bracket 1
- User's manual 1

Specifications

PV/SP data display	4-digits PV/SP separately	
PV input	Method	Universal input
	Thermocouple	K, J, T, E, R, S, B, N, L, U, Platinel 2
	RTD	Pt100, JPt100
	Voltage	0 to 100mV, 0 to 5V, 1 to 5V, 0 to 10V
Input accuracy	Thermocouple	±2°C ±1digit
	RTD	±1°C ±1digit
	Voltage (mV, V)	±0.3% ±1digit
Sampling period	500ms	
Number of program pattern	1 program pattern	
Number of program segment	16 segment	
Program time span	0 second to 1,599 hour	
Accuracy of program time span	±2% of program time span	
Control output	Method	When ordering, specify control output
	Relay output	Time-proportional PID or ON/OFF
	Voltage pulse output	Time-proportional PID
	4 to 20 mADC output	Continuous PID
Event output	Number of points	2 relay outputs
	Type	PV event and time event
Power supply	100 to 240 VAC or 24VAC/DC(option)	
Safety and EMC standard	CSA, CE and UL	
Construction (front protection)	IP65	
Dimensions and weight	48(W)X48(H)X100(D)mm, approx. 200g	
Option	External contact input (when /EX is specified)	Run/Reset, Hold/Cancel Hold
	PV retransmission output, can be scaled (when /RET is specified)	4 to 20 mADC
	RS485 communication (when /RS is specified)	MODBUS/Ladder/PC-link protocol
	24V Power supply (when /V24 is specified)	24V DC / 24V AC

Measured Value Input

The UP150 allows you to freely change the input type by software.

UP150 Measured Input Ranges

Input type	Range (°C)	Range code (°C)	Range (°F)	Range code (°F)	
Unspecified		OFF			
Thermocouple	K	-270 to 1370°C	1	-300 to 2500°F	31
		0.0 to 600.0°C	2	32.0 to 999.9°F	32
		0.0 to 400.0°C	3	32.0 to 750.0°F	33
		-199.9 to 200.0°C	4	-300 to 400°F	34
	J	-199.9 to 999.9°C	5	-300 to 2100°F	35
	T	-199.9 to 400.0°C	6	-300 to 750°F	36
	E	-199.9 to 999.9°C	7	-300 to 1800°F	37
	R	0 to 1700°C	8	32 to 3100°F	38
	S	0 to 1700°C	9	32 to 3100°F	39
	B	0 to 1800°C	10	32 to 3200°F	40
	N	-200 to 1300°C	11	-300 to 2400°F	41
	L	-199.9 to 900.0°C	12	-300 to 1600°F	42
	U	-199.9 to 400.0°C	13	-300 to 750°F	43
	Platinel 2	0 to 1390°C	14	32 to 2500°F	44
RTD	Pt100	-199.9 to 850.0°C	15	-199.9 to 999.9°F	45
		0.0 to 400.0°C	16	32.0 to 750.0°F	46
		-199.9 to 200.0°C	17	-300 to 400°F	47
		-19.9 to 99.9°C	18	-199.9 to 999.9°F	48
JPt100	-199.9 to 500.0°C	19			
DC voltage	0 to 100mV	0.0 to 100.0	20		
		0 to 5V	0.000 to 5.000	21	
		1 to 5V	1.000 to 5.000	22	
		0 to 10V	0.00 to 10.00	23	
			User-scalable		

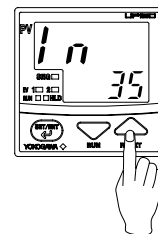

For example, to select thermocouple type J (°F), set the range code to 35.

Hardware Specifications

Measured Value (PV) Input

- Input: 1 point
 - Input type: Universal; can be selected by software
 - Input accuracy (at 23±2°C ambient temperature)
 - Thermocouple: ±2°C ±1digit
 - However,
 - ±4°C for thermocouple input -200 to -100°C
 - ±3°C for thermocouple input -100 to 0°C
 - ±5°C for types R and S (±9°C for 0 to 500°C)
 - ±9°C for type B (accuracy is not guaranteed for 0 to 400°C)
 - RTD: ±1°C ±1digit
 - Voltage(mV, V) : ±0.3% ±1digit
 - Sampling period for measured value input: 500ms
 - Burn-out detection: Functions for thermocouple or RTD input (burn-out upscale only; cannot be switched off)
 - Input resistance: 1MΩ or greater for thermocouple or DC mV input. Approx. 1MΩ for DC V input
 - Maximum allowable signal source resistance : 250Ω for thermocouple or DC mV input 2kΩ for DC V input
 - Maximum allowable wiring resistance for RTD input: 10Ω/wire (The resistance values of three wires must be the same.)
 - Allowable input voltage: ±10V DC for thermocouple or DC mV input ±20V DC for DC V input
 - Noise rejection ratio: Normal mode noise: Min. 40dB (50/60Hz) Common mode noise: Min. 120dB (Min. 90dB for DC V input)
 - Error of reference junction compensation: ±1.5°C (at 15-35°C) ±2.0°C (at 0-50°C)
- The reference junction compensation cannot be switched off.
- Applicable standards: Thermocouple and resistance temperature detector(RTD) JIS/IEC/DIN (ITS90)

Contact Inputs

- The contact inputs are provided only when the /EX option is specified.
- Functions: (1) HOLD/Cancel HOLD switching (2) RUN/RESET switching
 - Input: 2 points (with the shared common terminal)
 - Input type: Non-voltage contact or transistor contact input
 - Contact capacity: At least 12V/10mA
 - On/off judgment: On state for 1kΩ or less; off state for 20kΩ or greater

Control Output

- Output: 1 point
- Output type: Choose one from (1) to (3) below:
 - (1) Relay contact output
Contact capacity: 3A at 240V AC or 3A at 30V DC (with resistance load)
Note: The control output relay cannot be replaced by users.
 - (2) Voltage pulse output
On voltage: 12-18V DC (load resistance: 600Ω or greater)
Off voltage: 0.1V DC or less (short-circuit current: approx. 30mA)
 - (3) Current output
Output signal: 4 to 20mA
Maximum load resistance: 600Ω
Output accuracy: ±0.3% of span (at 23±2°C ambient temperature)

Event Functions

- **PV Event Functions**
PV event types: 10 types
PV high limit, PV low limit, Deviation high limit, Deviation low limit, De-energized on deviation high limit, De-energized on deviation low limit, Deviation high and low limits, Deviation within high and low limits, De-energized on PV high limit, De-energized on PV low limit
- **Time Event Functions**
The time event function begins countdown when a program operation starts, and after the elapse of a preset time, outputs an on-time event signal (contact output: ON) or off-time event signal (contact output: OFF).
- PV and Time event outputs: 2 relay contacts
Relay contact capacity: 1A at 240V AC or 1A at 30V DC (with resistance load) (COM terminal is common)
Note: The PV and time event output relays cannot be replaced by users.

Accuracy of Program Time

±2% of program time

Retransmission Output

- The retransmission output is provided only when the /RET option is specified.
- Output signal: Measured value in 4-20mA DC, can be scaled.
 - Maximum load resistance: 600Ω
 - Output accuracy: ±0.3% of span (at 23±2°C ambient temperature)

Communication Function

The communication function is provided only when the /RS option is specified. (For details, read the user's manual of the communications functions IM 05C01E12-10E.)

- **Communication Protocol**
 - Personal computer link: Used for communication with a personal computer, or UT link module of the FA-M3 controller (from Yokogawa Electric Corporation).
 - Ladder communication: Used for communication with a ladder communication module of the FA-M3, or a programmable controller (PLC) of other manufacturers.
 - MODBUS communication: Used for communication with equipment featuring the MODBUS protocol.

Communication Interface

- Applicable standards: Complies with EIA RS-485
- Number of controllers that can be connected: Up to 31
- Maximum communication distance: 1,200m
- Communication method: Two-wire half-duplex, start-stop synchronization, non-procedural
- Baud rate: 2400, 4800, or 9600 bps

Safety and EMC Standards

- Safety: Comforms to IEC1010-1: 1990 and EN61010-1: 1992
Approved by CSA1010 for installation category CAT II (IEC1010-1) Certified for UL508
- EMC standards: Complies with EN61326
The UP150 program temperature controller conforms to the standards specified under the following conditions.
 - All wires except those for the power supply and relay contact output terminals are shielded.
 - The controller does not fluctuate more than 20% even when noise is applied.

Power Supply and Isolation

Power Supply

Power supply	Voltage	Rated at 100-240VAC (±10%) AC/DC 24V, 20 to 29V of allowable range when "V24" is specified.
	Frequency	50 or 60Hz
Maximum power consumption		8VA max. (4W max.) 3W max. when "V24" is specified.
Memory		Non-volatile memory
Withstanding voltage	Between primary terminals and secondary terminals (See Notes 1 and 3.)	1500V AC for 1 minute (See Note 2.)
Insulation resistance	Between primary terminals and secondary terminals (See Notes 1 and 3.)	20MΩ or more at 500V DC

Note 1: The primary terminals are the power supply terminals and event output terminals.

The secondary terminals are the analog input and output terminals, the voltage pulse output terminals, and the contact input terminals.

Note 2: The withstanding voltage is specified as 2300 V AC per minute to provide a margin of safety.

Note 3: AC/DC 24V terminals are secondary terminals.

Isolation

The bold lines below indicate reinforced isolation, and the broken line indicates functional isolation.

<ul style="list-style-type: none"> • Power supply terminals (100-240V AC) 	<ul style="list-style-type: none"> • Power supply terminals AC/DC 24V (When "V24" is specified)
<ul style="list-style-type: none"> • Control output terminals (relay contacts) 	<ul style="list-style-type: none"> • Measured value input terminals • 2 input terminals for /EX • Internal circuit
<ul style="list-style-type: none"> • Event output terminals (2 relay contacts) 	<ul style="list-style-type: none"> • Control output terminals: 4-20 mA/Voltage pulse • Retransmission output terminals: 4-20 mA • RS-485 terminals for /RS

Note: Neither the measured value input terminals, nor 2 input terminals for the /EX option are isolated from the internal circuit.

Construction, Mounting, and Wiring

- Construction: Dust-proof and splash-proof front panel (compliant with IP65). Splash-proof construction is not available for side-by-side close mounting.
- Case color: Black
- Case color: Black
- Weight: approx. 200g
- Mounting: Flush panel mounting
- Wiring: Screw terminals

Environmental Conditions

Normal Operating Conditions

- Warm-up time: At least 30 minutes
- Ambient temperature: 0-50°C (0-40°C when mounted side-by-side)
- Rate of change of temperature: 10°C/h or less
- Ambient humidity: 20-90% RH (no condensation allowed)
- Magnetic field: 400A/m or less
- Continuous vibrations of 5 to 14Hz: Amplitude of 1.2mm or less
- Continuous vibrations of 14 to 150Hz: 4.9m/s² (0.5G) or less
- Short-period vibrations: 14.7m/s² (1.5G) for 15 seconds or less
- Shock: 98m/s² (10G) for 11 milliseconds or less
- Mounting angle: Upward incline of up to 30 degrees; downward incline is not allowed.
- Altitude: 2000m or less above sea level

Maximum Effects from Operating Conditions

- (1) Temperature effects
 - Thermocouple, DC mV and DC V input: ±2μV/°C or ±0.02% of F.S./°C, whichever is larger
 - Resistance temperature detector: ±0.05°C/°C
 - Analog output: ±0.05% of F.S./°C
- (2) Effect from fluctuation of power supply voltage (within rated voltage range)
 - Analog input: ±0.2μV/V or ±0.002% of F.S./V, whichever is larger
 - Analog output: ±0.05% of F.S./V

Transportation and Storage Conditions

- Temperature: -25 to 70°C
- Humidity: 5 to 95% RH (no condensation allowed)
- Shock: Package drop height 90cm (when packed in the dedicated package)

■ Display and Operation Functions

SEG lamp (green)
Lit when the value of segment no. or remaining segment time is displayed on SP display.

EV1, EV2 lamps (red)
EV1 : Lit when event 1 (PV event 1 or Time event 1) is activated.
EV2 : Lit when event 2 (PV event 2 or Time event 2) is activated.

RUN lamp (orange)
Lit while the operation mode is "RUN".
Flashing while the operation mode is "WAIT".

HLD (hold) lamp (green)
Lit while the operation mode is "HOLD".

SET/ENT key (data registering key)

- Switches the operating displays.
- Registers the data value changed using the data change keys.
- Switches between parameter setting displays sequentially.
- Pressing the key for 3 seconds or longer in the operating display retrieves the operating parameter setting display.
- Pressing the key for 3 seconds or longer in operating, setup or program parameter setting display transfers back to operating display.

PV display (red)
Indicates PV (measured value) and character information such as parameter codes and error codes. Indicates PV and "AT" alternately during Auto-tuning.

SP display (green)
Indicates SP (target setpoint), segment no., remaining segment time and parameter setpoints.

Data change key (or Reset key)

- Pressing this key for more than 1 second (in operating display) stops (resets) the program operation.
- Changes the program setpoints(SP) and the parameter setpoints.
- Pressing this key increases the parameter setpoint. Holding down the key will gradually increase the speed of changes.

Data change key (or Run key)

- Pressing this key for more than 1 second (in operating display) starts (runs) the program operation.
- Changes the program setpoints(SP) and the parameter setpoints.
- Pressing this key decreases the parameter setpoint. Holding down the key will gradually decrease the speed of changes.

■ Communication Functions

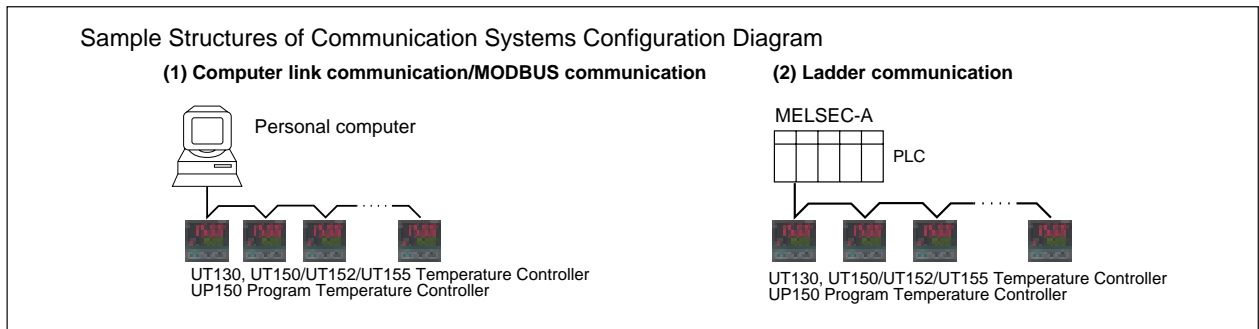

■ Function Block Diagram

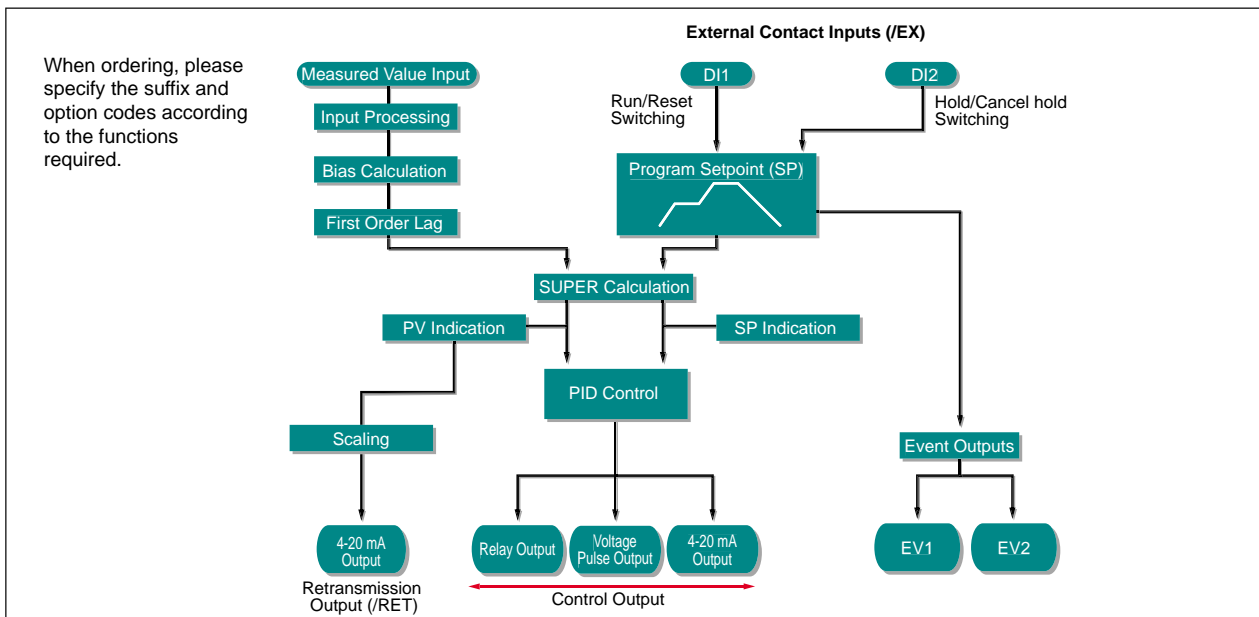

External Dimensions and Panel Cutout Dimensions

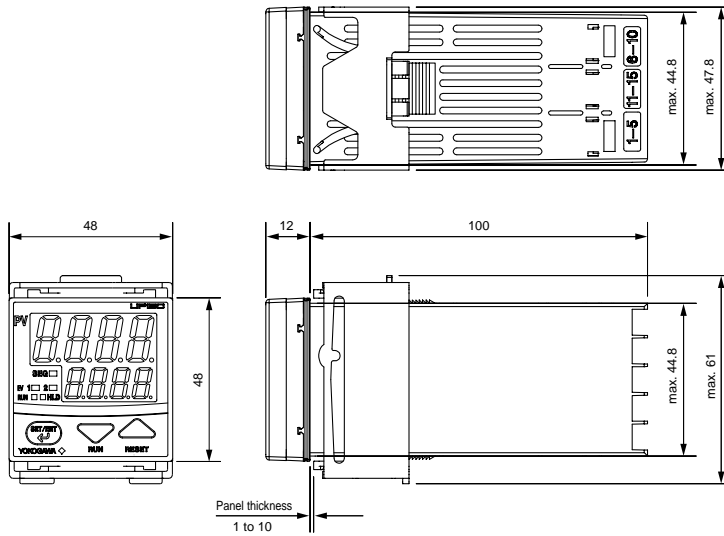

1. General Mounting

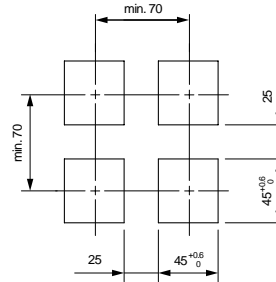

2. Side-by-side Close Mounting (Splash-proof construction is unavailable)

Unit: mm

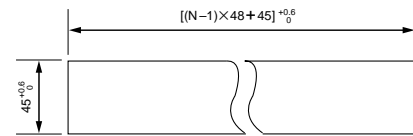

N is the number of controllers.
If N≥5, then measure the actual length.

Terminal Arrangements

