

# General Specifications

## MODEL UM350 Digital Indicator with Alarms



GS 05F01D02-01E

### ■ General

Model UM350 Digital Indicator with Alarms is a precision alarm instrument with universal input. For excellent monitoring operability, it displays process variables on a large display. It is also provided with four alarm setting points (one is optional). A retransmission output and 15 V DC loop power supply are provided as standard. A communication function or 24 V DC loop power supply is available optionally.

### ■ Main Features

- Extra-large digital display allows the indicated values to be read even from a long distance. LEDs of 20mm height are used for the process variable display.
- Universal input allows simple setting of the input types (TC, RTD, mV) or input measuring range.
- Various communication function are provided. Communication is possible with personal computer, programmable logic controller, and other controllers.

### ■ Function Specifications

#### ● Signal Computation Function

Measured input computation:

Bias addition (-100.0 to 100.0% of measured input range width.), first order lag filter (time constant off, 1 to 120s.)

Contact input: Retains and displays maximum and minimum readings from measured variable. Resets the maximum and minimum readings.

#### ● Alarm Function

Six different types of alarms are provided. If an alarm occurs, the alarm lights up. Four (one is optional) of the six can be used as relay contact outputs.

Alarm types:

PV high limit, PV low limit, Deenergized on PV high limit, Deenergized on PV low limit, Fault diagnosis, and FAIL output

Setting ranges for process variable alarms:

PV alarms: -100.0 to 100.0% of measured input range

Alarm hysteresis width: 0.0 to 100.0% of measured input range width

Fault diagnostic alarm: Input burnout, A/D conversion error, TC RJC error

FAIL output: Software failure, hardware failure

UM350



UM350E

"E" indicates the model with expanded functions.

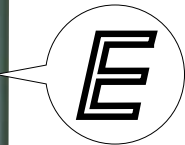

Delay timer:

0.00 to 99.99 (minute, second)

An alarm is output when the delay timer expires after the alarm setpoint is reached. Setting for each alarm is possible.

Stand-by action:

Stand-by action can be set to make PV alarm OFF during start-up.

#### ● Display and Operation Functions

PV display:

4-digit digital display for engineering data

Parameter display:

4-digit digital display for various data, including parameters

Status display: 4 alarm LEDs (AL1, AL2, AL3, AL4)

Operation key:

△ and ▽ keys: Increase/decrease setpoints or various parameters.

SET/ENT key: Sets setpoint data, calls or switches various parameters.

SELECT display:

Allows selection and registration of frequently changed parameters from the operation parameters during operation. For example, if the alarm-1 setpoint is registered in the SELECT display, the setpoint can easily be displayed during operation.

Security function:

An operation-inhibiting mode using a password is provided.

● **Communication Functions (optional)**

The communication function, provided with the instrument, allows connection to personal computer, and programmable logic controller.

- Communication protocol
  - Computer link communication:
    - Communication protocol with a personal computer.
  - Ladder communication:
    - Communication protocol with programmable logic controller
  - MODBUS communication:
    - Communication protocol with a personal computer, or PLC.
- Communication interface
  - Communication protocol:
    - Computer link or ladder communication
  - Standard: EIA RS485
  - Maximum number of connectable controllers:
    - 31 GREEN series controllers
  - Maximum communication distance: 1,200 m
  - Communication method:
    - Two-wire half duplex, or four-wire half duplex, start-stop synchronization system, handshaking
  - Communication rate: 600, 1200, 2400, 4800, 9600 bps

■ **Hardware Specifications**

**Measured input signal**

- Number of inputs: 1
- Input type, measurement range, and measurement accuracy:
  - The type of input and measurement range can be specified using the input range code shown in the table next page by front key operation or communication.
- Sampling period: 250ms
- Burnout detection:
  - Available with TC, RTD, standard signal, 0.4 to 2V DC and 1 to 5V DC.
  - Up-scale, down-scale, and off can be set.
  - For standard signal, an input of 0.1V or less is regarded as burnout.
- Input bias current: 0.05  $\mu$ A (for TC and RTD b-terminal)
- Measuring current(RTD): about 0.13mA
- Input resistance:
  - TC/mV: 1 M $\Omega$  or more
  - DC voltage input: about 1 M $\Omega$
- Allowable signal source resistance:
  - TC/mV input: 250 $\Omega$  or less
  - Effect from allowable signal source resistance: 0.1  $\mu$ V/  $\Omega$  or less

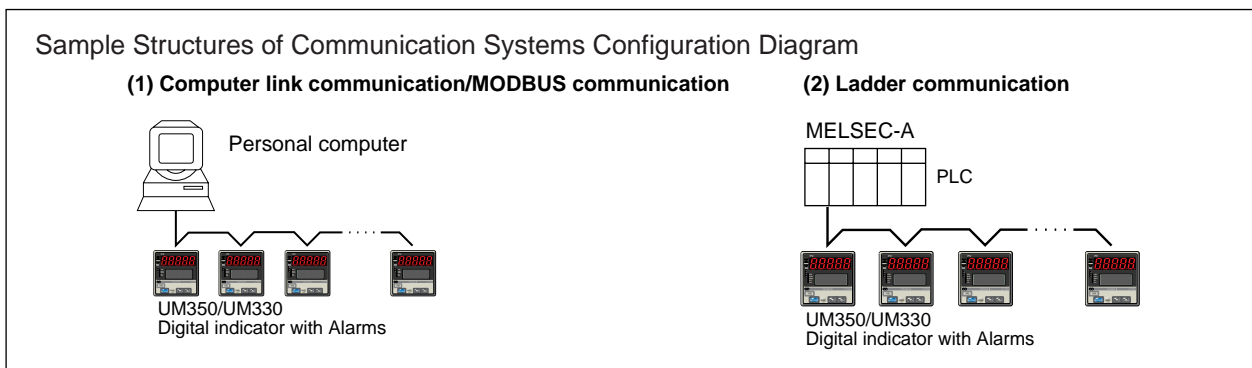
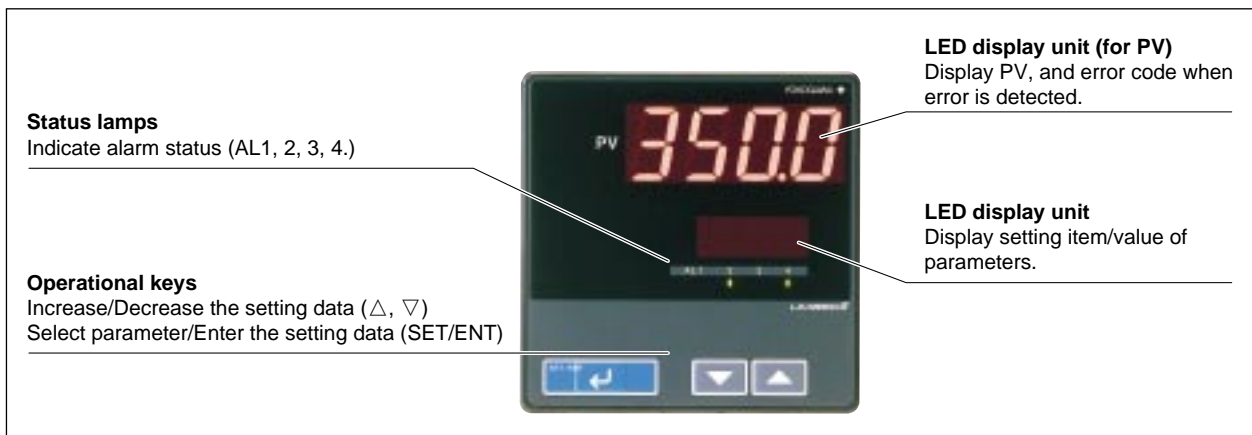

DC voltage input: 2 kΩ or less  
 Effect from allowable signal source resistance: 0.01%/100Ω or less  
 Allowable leadwire resistance:  
 RTD 150Ω/wire or less (provided that there is no variation between the three wires.)  
 For the range of -150.0 to 150.0, 10Ω/wire  
 Effect from allowable leadwire resistance: ±0.1°C/ 10Ω or less  
 Allowable input voltage:  
 TC/mV/RTD ±10V DC  
 DC voltage ±20V DC  
 Noise rejection ratio:  
 Normal mode 40dB (50/60Hz) or more  
 Common mode 120dB (50/60Hz) or more  
 Reference-junction compensation error:  
 ±1.0°C (15 to 35 °C),  
 ±1.5°C (0 to 15°C, 35 to 50°C)  
 Applicable standard: For TC and RTD, JIS, IEC, DIN(ITS-90)

**24V DC Loop Power supply for sensor**

Supplies power to the 2-wire transmitter. A resistor (10 to 250 Ω) is to be placed between the alarm unit and transmitter. Current signals are converted into voltage signals, and read through the process input.

Power supply voltage 21.6 to 28.0 V DC; maximum supply current about 30 mA. (only for models with 24 V DC loop power supply)

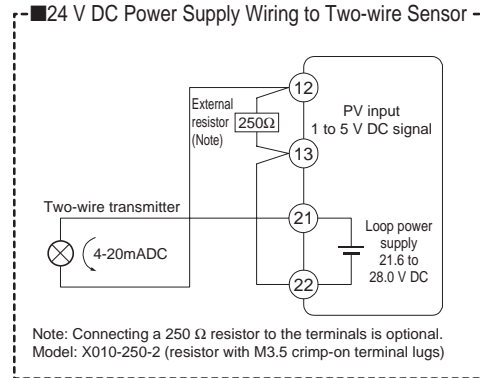

Input type		Input range code	Instrument range (°C)	Instrument range (°F)	Instrument accuracy*1
Unspecified(when shipped from the factory)		OFF	Set the data item PV input type "IN" to the OFF option to leave the PV input type undefined.		
Thermocouple	K	1	-200 to 1370°C	-300 to 2500°F	At or above 0°C ±0.1% ±1 digit of F.S. Below 0°C, ±0.2% ±1 digit of F.S.
		2	-199.9 to 999.9°C	0 to 2300°F	
		3	-199.9 to 500.0°C	-199.9 to 999.9°F	
	J	4	-199.9 to 999.9°C	-300 to 2300°F	
		T	5	-199.9 to 400.0°C	
	6		0.0 to 400.0°C	-199.9 to 750.0°F	
	B	7	0 to 1800°C	32 to 3300°F	At or above 400°C ±0.15% ±1 digit of F.S. Below 400°C ±5% ±1 digit of F.S.
	S	8	0 to 1700°C	32 to 3100°F	±0.15% ±1 digit of F.S.
	R	9	0 to 1700°C	32 to 3100°F	±0.15% ±1 digit of F.S.
	N	10	-200 to 1300°C	-300 to 2400°F	±0.1% ±1 digit of F.S. Below 0°C ±0.25% ±1 digit of F.S.
			-199.9 to 999.9°C	-300 to 1800°F	At or above 0°C ±0.1% ±1 digit of F.S. Below 0°C ±0.2% ±1 digit of F.S.
	L (DIN)	12	-199.9 to 900.0°C	-300 to 1300°F	±0.2% ±1 digit of F.S.
	U (DIN)	13	-199.9 to 400.0°C	-300 to 750°F	
			14	0.0 to 400.0°C	-199.9 to 750.0°F
	W (DIN)	15	0 to 2300°C	32 to 4200°F	±0.2% ±1 digit of F.S.
	Platinel 2	16	0 to 1390°C	32 to 2500°F	±0.1% ±1 digit of F.S.
	PR20-40	17	0 to 1900°C	32 to 3400°F	At or above 800°C ±0.5% ±1 digit of F.S. Below 800°C, not guaranteed
	W97Re3-W75Re25	18	0 to 2000°C	32 to 3600°F	±0.2% ±1 digit of F.S.
RTD	JPt100	30	-199.9 to 500.0°C	-199.9 to 999.9°F	±0.1% ±1 digit of F.S. (Note1) (Note2)
		31	-150.0 to 150.0°C	-199.9 to 300.0°F	±0.2% ±1 digit of F.S. (Note1)
	Pt100	35	-199.9 to 850.0°C	-300 to 1560°F	±0.1% ±1 digit of F.S. (Note1) (Note2)
		36	-199.9 to 500.0°C	-199.9 to 999.9°F	±0.2% ±1 digit of F.S. (Note1)
		37	-150.0 to 150.0°C	-199.9 to 300.0°F	
Standard signal	0.4 to 2V	40	0.400 to 2.000 V	Scaling is enable in the following 4 range. -1999 to 9999 -199.9 to 999.9 -19.99 to 99.99 -1.999 to 9.999	±0.1% ±1 digit of F.S.
	1 to 5V	41	1.000 to 5.000 V		
DC voltage	0 to 2V	50	0.000 to 2.000 V		
	0 to 10V	51	0.00 to 10.00 V		
	-10 to 20mV	55	-10.00 to 20.00 mV		
	0 to 100mV	56	0.0 to 100.0 mV		

Note 1: The accuracy is ±0.3°C of instrument range ±1 digit for a temperature range from 0 to 100°C

Note 2: The accuracy is ±0.5°C of instrument range ±1 digit for a temperature range from -100 to 200°C .

\*1: Performance in the standard operating conditions (at 23±2°C, 55±10% RH, and 50/60Hz power frequency)

**Retransmission output**

Either PV or target setpoint is outputs.

Either this or the 15V DC loop power supply is available.

Number of output points: 1  
 Output signal: 4 to 20 mA DC  
 On-load resistance: 600 Ω or less  
 Output accuracy: ±0.3% of span  
 Performance in the standard operating conditions (at 23±2°C, 55±10% RH, and 50/60 Hz power frequency)

15V DC loop power supply:

Power supply voltage 14.5 to 18.0 V DC; maximum supply current about 21 mA. (Safety circuit against short-circuiting in the field)

**Contact input**

Usage: Resets the displayed maximum and minimum process variables.

Number of inputs: 1 point

Input type: Non-voltage contact input or transistor contact

Input contact rating: 12V DC, 10mA or more (for non-voltage contact input)

On/off determination: For non-voltage contact input,  
 ON = contact resistance of 1 kΩ or less,  
 OFF = contact resistance of 20 kΩ or more.  
 For transistor contact input,  
 ON = 2V or less,  
 OFF = leak current of 100μA or less.

Minimum retention time for status detection: about 1 s.

**Contact outputs**

Usage: Alarm output, FAIL output

Number of relay contact outputs:  
 4 points (alarm -4 is optional)

Alarm -1 to -3 relay contact rating:  
 240 V AC 1A, or 30 V DC 1 A, make contact

Alarm -4 relay contact rating:  
 250 V AC 3 A, or 30 V DC 3 A (load resistance)  
 Output signal: 3 terminals (NC, NO, Common), transfer contact

**● Display Unit Specifications**

Process variable display unit:  
 4-digit 7-segment red LED, each digit 20 mm in height

Parameter display:  
 4-digit 7-segment red LED, each digit 9.3 mm in height

Status indicating lamps: LEDs

**● Conformance to Safety and EMC standards**

Safety standard:  
 Conforms to IEC1010-1: 1990 and EN61010-1: 1992.  
 Certified for CSA1010,  
 The overvoltage category of each input is CAT II (IEC1010-1),  
 Certified for UL 508

EMC standards:  
 Conforms to the following EMC standards.  
 During test, the controller continues to operate with the measurement accuracy within ±20% of the range.  
 EMI (Emission) EN61326-1: 1997+Am1: 1998  
 EMS (immunity) EN61326-1: 1997+Am1: 1998

**● Construction/Installation/Wiring**

Structure: Dust-proof and Drip-proof front panel conforming to IP55.  
 For side-by-side close installation, controller loses its dust-proof and drip-proof protection.

Body construction: ABS resin and polycarbonate

Case color: Black

Weight: Approx. 1 kg or less

Dimensions: 96W × 96H × 100D (from the front panel) (mm)

Mounting: Direct panel mounting; mounting bracket, one each for upper and lower mounting.

Panel cutout dimensions: 92<sup>+0.8</sup><sub>0</sub> (W) × 92<sup>+0.8</sup><sub>0</sub> (H) mm

Mounting attitude: Up to 30 degrees above the horizontal.  
 No downward tilting allowed.

Wiring: M3.5 screw terminal (signals, power supply/ground)

**● Power supply / Isolation**

Power supply: Voltage rating at 100 to 240 V AC (±10%), 50/60 Hz

Power consumption: MAX. 20 VA (MAX. 8.0 W)

Memory backup: Non-volatile memory (Service life approx. 100,000 times of writings)

Withstanding voltage:

Between primary terminal and secondary terminal:  
 1500 V AC for 1 min. (Note)

Between primary terminal and ground terminal:  
 1500 V AC for 1 min. (Note)

Between ground terminal and secondary terminal:  
 1500 V AC for 1 min.

Between two secondary terminals:  
 500V AC for 1min.

(Primary terminal:  
 Power supply, relay output  
 Secondary terminal:  
 Analog input/output signal terminals,  
 contact input terminal)

Note. The withstand voltage is specified as 2300V AC per minute to provide a margin of safety.

Isolation resistance: Between power supply terminal and ground terminal, 500 V DC, 20 MΩ or more

Ground: Class 3 grounding (grounding resistance of 100Ω or less)

Isolation specifications

Measured input terminal:  
 Isolated from other input/output terminals.  
 Not isolated from the internal circuit.

24 V DC loop power supply terminal for sensor:  
 Isolated from other input/output terminals and internal circuit.

Retransmission output terminal:  
 Isolated from other input/output terminals and internal circuit.

Contact input terminal:  
 Not isolated from communication terminals.  
 Isolated from other input/output terminals and internal circuit.

Relay contact output terminal:  
 Isolated from other input/output terminals and internal circuit.

RS-485 communication terminals:  
 Not isolated from contact input terminals.  
 Isolated from other I/O terminals and internal circuit.

Power supply terminal:  
Isolated from other input/output terminals  
and internal circuit.

Ground terminal:  
Isolated from other input/output terminals  
and internal circuit.

### Environmental Conditions

Normal operating conditions:  
Ambient temperature: 0° to 50°C (less than 40°C when  
mounted side by side)  
Temperature change limit: 10°C/h or less  
Ambient humidity: 20 to 90% RH (non-condensing)  
Magnetic field: 400 A/m or less  
Continuous vibration (5 to 14 Hz):  
Amplitude of 1.2 mm or less  
Continuous vibration (14 to 150 Hz):  
4.9 m/s<sup>2</sup> or less  
Short - period vibration: 14.7 m/s<sup>2</sup>, 15 s. or less  
Shock: 147 m/s<sup>2</sup> or less, 11 ms.  
Installation altitude:  
2,000 m above sea level maximum  
Warm-up time: 30minutes or more.

Transit/storage conditions  
Temperature: -25° to 70°C  
Temperature change limit: 20°C/h or less  
Humidity: 5 to 95% RH (non-condensing)

Effects on operating conditions  
Effect of ambient temperature:  
For voltage/TC input, within  $\pm 1 \mu\text{V}/^\circ\text{C}$  and  
 $\pm 0.01\%$  of F.S./°C, whichever is greater.  
For RTD input, within  $\pm 0.05^\circ\text{C}/^\circ\text{C}$   
(ambient temperature)  
For analog output,  $\pm 0.05\%$  of F.S./°C or  
less

Effect on power supply fluctuation (within rated  
voltage range):  
For analog input, within  $\pm 1 \mu\text{V}/10\text{V}$  and  
 $\pm 0.01\%$  of F.S./10V, whichever is greater.  
For analog output, within  $\pm 0.05\%$  of F.S./  
10V

# Standard Type, Terminal Arrangements

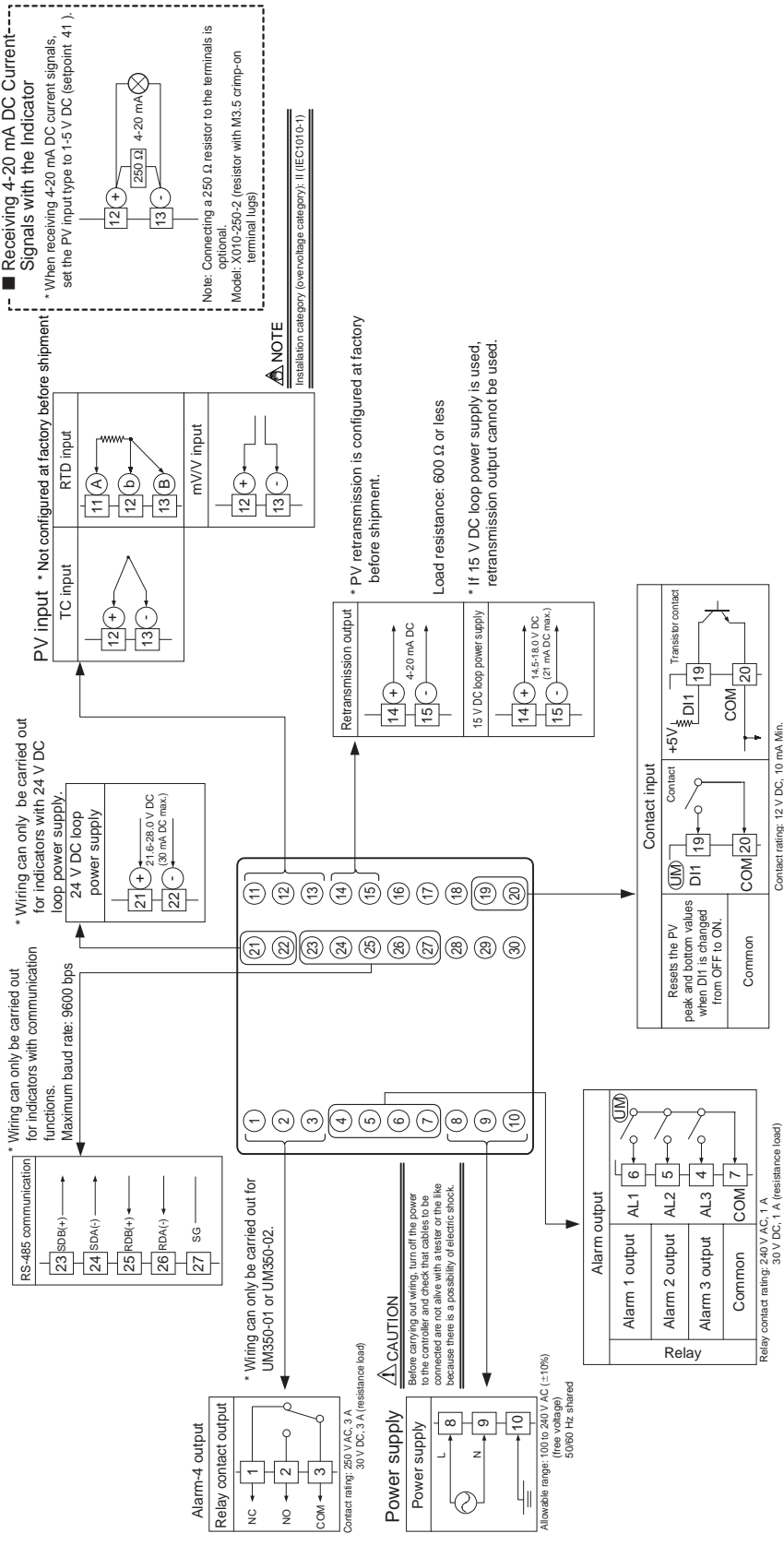

## External Dimensions and Panel Cutout Dimensions

Unit: mm

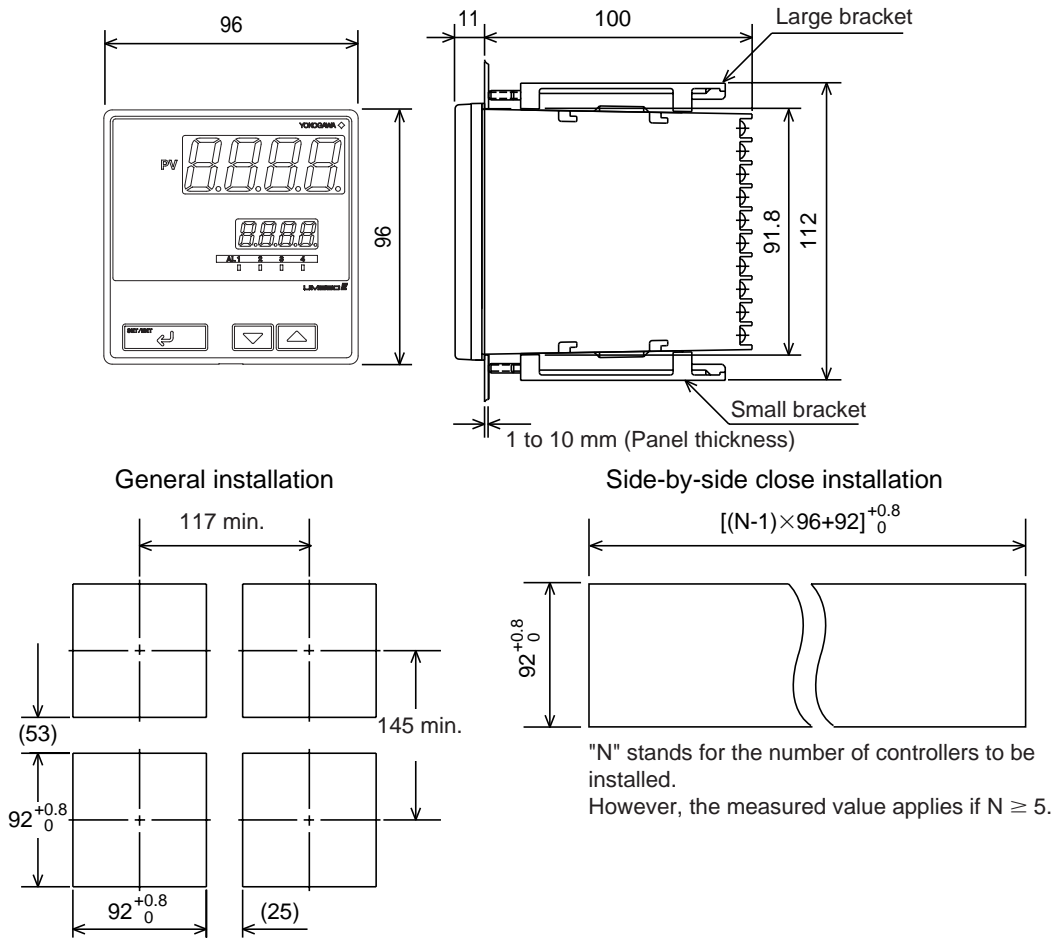

## Model and Suffix Codes

Model	Suffix Code	Description
UM350		Digital indicator with Alarms (provided with retransmission output and 15 V DC loop power supply as standard)
Type	-0 -3	Standard type with three alarms Standard type with three alarms (with a 24 V DC loop power supply)
Optional functions	0 1 2	None Communication and additional alarm-4 Additional alarm-4

Standard accessories: Brackets (mounting hardware), unit label, and User's Manuals.

## Items to be specified when ordering

Model and suffix code, necessary/unnecessary of User's Manual or QIC.