

**Superior**  
Electric

TVSS Series STABILINE®  
Transient Voltage Surge Suppressors



VARIABLE TRANSFORMERS • VOLTAGE REGULATORS • POWER CONDITIONERS • LIGHTING CONTROLS • UNINTERRUPTIBLE POWER SUPPLIES

# TVSS Series STABILINE® Surge S

ANSI/IEEE standard C62.41-1991 separates a typical facility into three location categories, each characterized by differing exposure levels, types of transient wave shapes, voltage/current levels and by transient source.

The diagram below illustrates category C, B & A locations with transient voltage surge suppression.

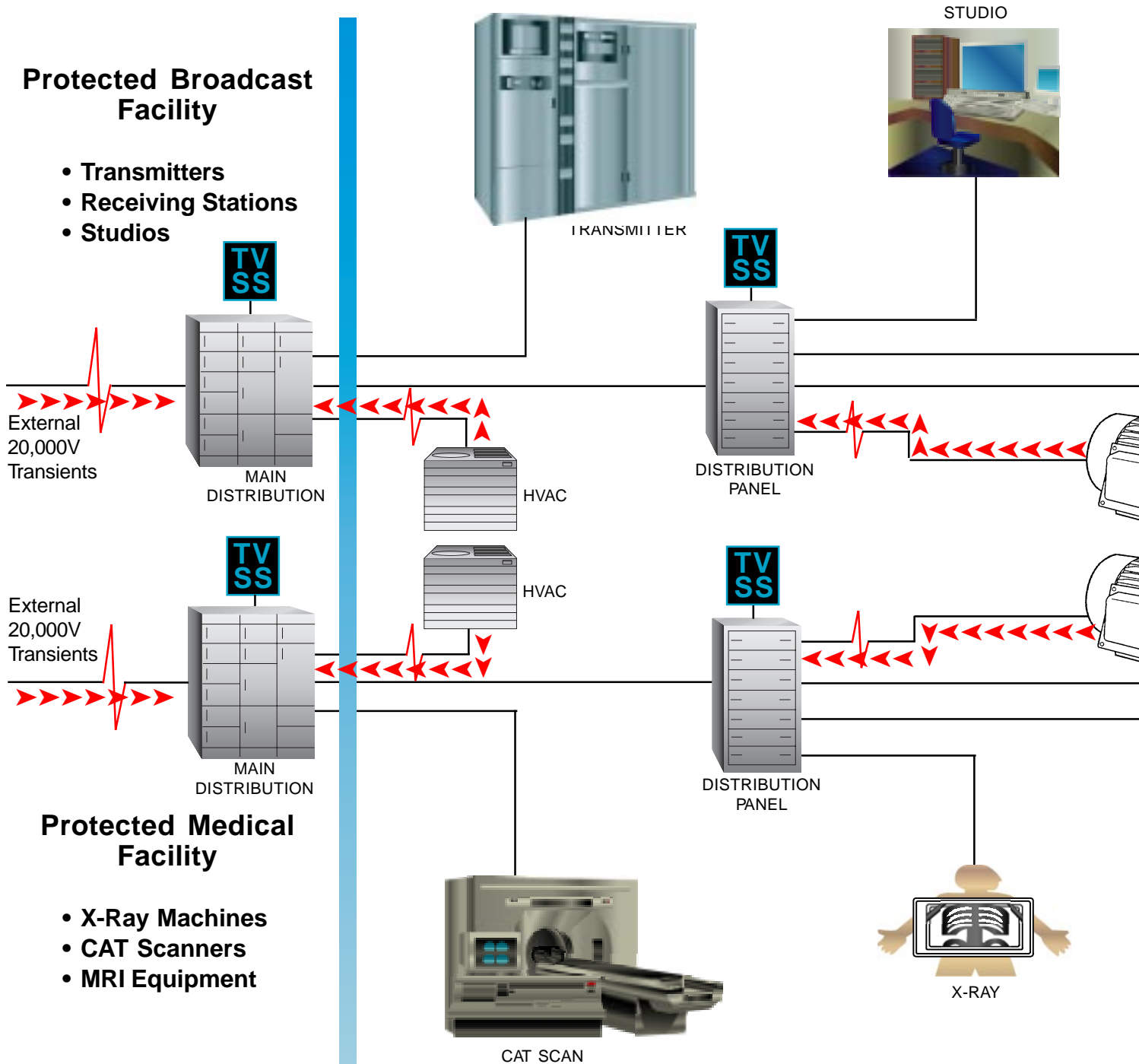

## Category C

Category C locations are subject to heavy, externally generated impulse transients resulting from events such as lightning, power company grid switching, power system faults, severe weather and neighboring facilities.

## Category B

Category B locations are subject to a mixture of externally generated impulse transients, internally generated switching and ring wave transients generated by a broad spectrum of load as motors, environmental control equipment, manufacturing and office equipment.

# Suppression Solutions

Contact your Superior Electric factory trained representative to assist you with the evaluation of your needs.

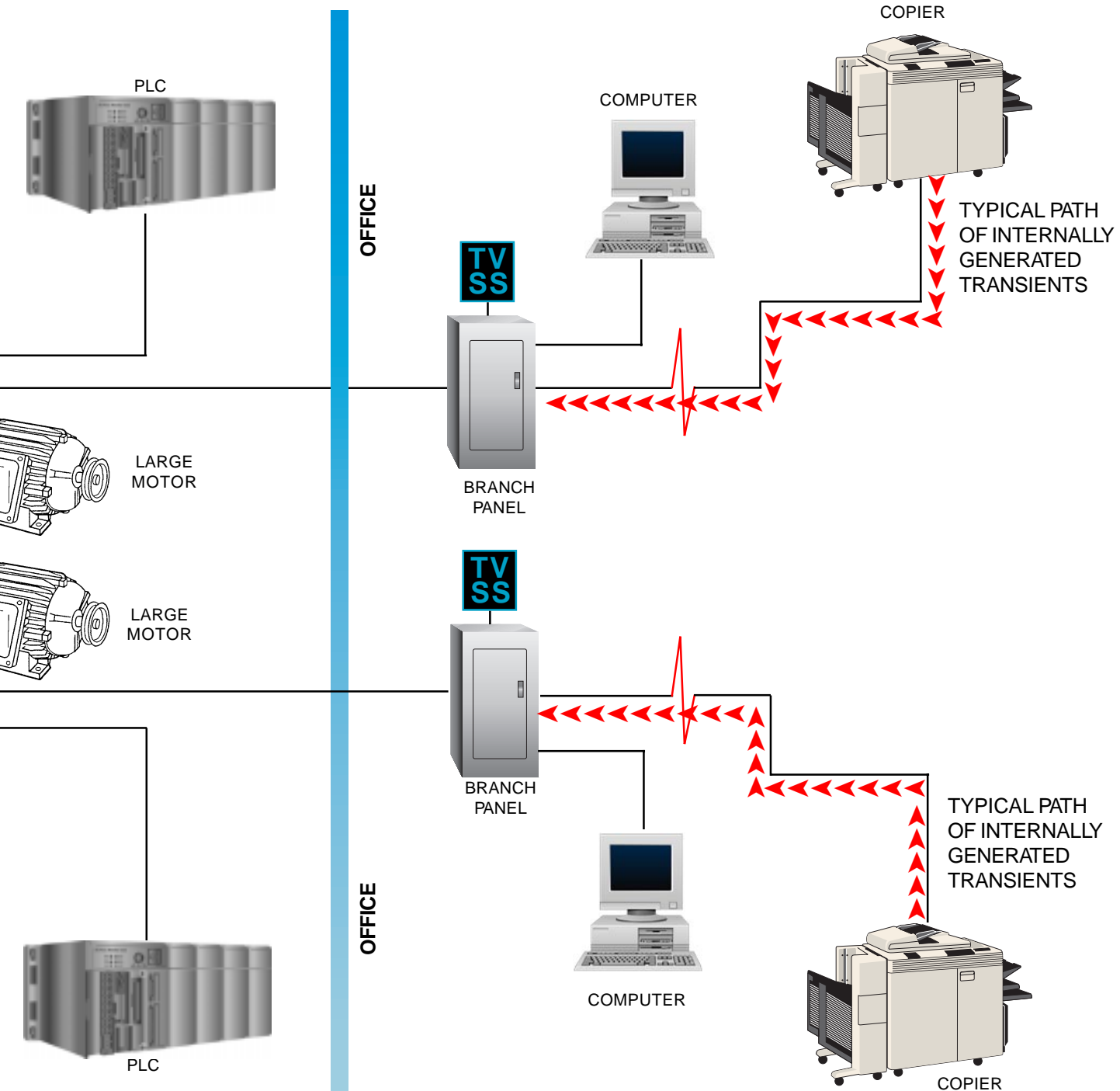

## Category A

Category A locations are subject to a high level of switching and ring wave transients generated from a wide variety of load equipment, including office equipment and commercial and industrial manufacturing systems.

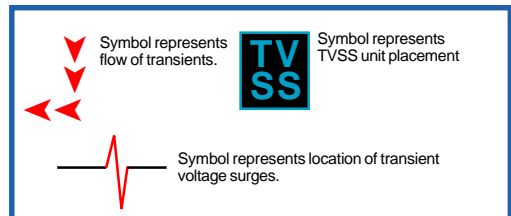

# TVSS Table of Contents

Protected Facility (Solution Diagram) .....	3 & 4
How Much is Enough? .....	5
Category Identification .....	5
Benefits & Features .....	6
Options .....	6
Type Number Designations .....	7
Options Ordering Instructions .....	7
<b>TVSS Series STABILINE® Transient Voltage Surge Suppressor Models</b>	
TVSS300 (300,000 amps) .....	8
TVSS250 (250,000 amps) .....	9
TVSS200 (200,000 amps) .....	10
TVSS150 (150,000 amps) .....	11
TVSS125 (125,000 amps) .....	12
TVSS100 (100,000 amps) .....	13
TVSS80 (80,000 amps) .....	14
TVSS60 (60,000 amps) .....	15
TVSS Hand-Held Tester .....	16

*Contact us with your Application:  
Tel: 860-585-4500 • Fax: 860-582-3784  
Web Site: [www.superiorelectric.com](http://www.superiorelectric.com)  
383 Middle Street • Bristol, CT 06010*

# TVSS How Much is Enough?

How much protection does your facility require? ANSI/IEEE C62.41 states that a “typical” service entrance transient can deliver a current magnitude of 10,000 amps. So why are products with hundreds of thousands of amps recommended for top-level protection?

Reliable data sources illustrate that some “non-typical” current magnitudes may be in excess of 200,000 amps. Additionally, lightning strikes often consist of four to six consecutive “hits” and may be as many as 40. Therefore, suppression filter systems must provide adequate protection to ensure that such events do not cause failure in the act of duty. Superior Electric products are designed to function as “permanent protection” when properly selected,

applied and installed. In addition to withstanding transients of large magnitudes, Superior Electric suppression filter systems are built to endure repetitive transient conditions. Recognizing that MOVs are finite elements when exposed to high currents, it’s easy to understand the importance of ensuring that each MOV is never stressed beyond life-threatening limits.

The only method of increasing MOV life expectancy is to reduce current exposure. Superior Electric’s TVSS units are designed with precise current sharing capabilities that will survive the routine transients while maintaining enough “horsepower” to handle episodes of large, catastrophic magnitude.

## TVSS Category Identification

### TVSS Series: Simple to select, easy to install

All Superior Electric suppression filter systems are manufactured and classified in accordance with the transient surge environments and surge severity guidelines specified in ANSI/IEEE standard C62.41-1991. The chart below defines ANSI/IEEE specified transient exposure levels, describes typical applications and suggests the appropriate TVSS product for each. The facility diagram represents the variety of exposure levels found within a typical building.

With basic understanding of your facility’s applications, electrical distribution system set-up and ANSI/IEEE exposure levels, suppression filter system requirements are easily determined. Your Superior Electric factory-trained representative will assist you with the evaluation of your needs.

IEEE Category	Exposure Level	Recommended Models	Typical Applications
“C”	Highest	TVSS300	• Zero-tolerance environments • Largest amperage capacity service entrances • Service entrances in high lightning areas
“C”	High	TVSS250	• Moderate and lower amperage capacity service entrances • Service entrances near utility substations • Service entrances on grid with other large industrial users • Service entrances remotely located from utility power factor correction and grid switching
“C”	High-to-Medium	TVSS200	• Distribution panels feeding rooftop loads in high lightning areas • Extremely large distribution panels
“B”	Medium	TVSS150 TVSS125	• Large distribution panels • Non-service entrance distribution panel-boards • Heavy equipment (UPS, elevators, etc.) located near unprotected service entrance • Panels feeding variable speed drives • Non-service entrance motor control centers utilizing drives, PLCs, soft-start starters, electronic starters, electronic control systems and electronic monitoring
“B”	Medium-to-Low	TVSS100	• Branch panels heavily loaded with sensitive electronic equipment • Branch panels with combination of dirty and sensitive loads • Branch panels with no upstream protection • Busway feeding sensitive loads • Bus riser feeding multiple floors with critical or sensitive loads
“B”	Low	TVSS80	• Branch panels with upstream protection • Branch panels with primarily sensitive electronic loading • Branch panels deep within a facility
“A”	Lowest	TVSS60	• Branch panels with upstream protection • Branch panels with primarily sensitive electronic loading

# TVSS Benefits & Features

## More features & benefits than competing models

TVSS Series STABILINE® Voltage Surge Suppressors offer models sized for applications from the highest to lowest exposure levels. Features and benefits include:

Seamless® Technology Engineering	Unique suppression and filtering properties of key components — MOVs, polypropylene capacitors and precise component geometry — are combined and maximized to deliver extended performance and reliability.
Failure-Free Integrated Suppression Bus®	Advanced suppression filter assembly eliminates PCB trace failures, enhances current sharing by minimizing impedance, conducts cumulative current via all-copper bus, then distributes to multiple MOV paths; individually fused MOVs. Suppression filter assembly enables TVSS models to provide unmatched performance and reliability. Unlike printed circuit board-based technologies, Superior Electric's patent-pending Failure-Free Integrated Suppression Bus is not dependent on PCB traces to carry full magnitude current. Instead, surge current travels on copper bus bars to multiple MOV (metal oxide varistor) paths, PCB trace failures are eliminated while current sharing is enhanced by minimized impedance. FEATURES: • Monitor output connectors — real-time monitoring of all modes • Heavy-duty filter capacitors ensure industry's best high frequency noise and transient filtering • Solid copper bus construction — cumulative surge current is carried on copper bus bars, thereby eliminating reliance on PCB trace to conduct full magnitude current • Fuse sensing circuitry • Internal fusing for uninterrupted protection at higher surge current levels - UL 248-1 Recognized fuse array rated at 200 kAIC (patented) - All paths and elements protected via fusing - Expanded safety and reliability via a fuse block array that prevents "cross-arcing" which may occur in designs without independently isolated fuses • Separately fused MOVs — ensures seamless product performance in event of single MOV failure • Power terminals • Sand-filled molded polycarbon suppression filter assembly enclosure
Direct bus connection	Permits connection directly to the serving electrical bus to minimize installation impedance and provides 200 kAIC fault current protection.
NEMA 4X fiberglass reinforced polyester or NEMA 4/12 metallic enclosure (with integral disconnect option only)	Allows installation in virtually any commercial or industrial environment
Phase indicator lights (3)	Indicates power present on each phase independently
Safety interlocked entry door	Prevents human exposure to energized unit (available only with integral disconnect)
All-modes protection	Ensures 100% protection by safeguarding all electrical modes (L-N, L-G, L-L, N-G)
Seven-Year Product Warranty	Warranted to be defect-free and performance-guaranteed for up to 7 years — even against lightning strikes

## TVSS Options

Integral disconnect (DM)



Safely removes unit power to facilitate testing, maintenance and inspection. Disconnect option includes metal enclosure. Safety interlocked to prevent accidental exposure to energized components.

Standard monitoring (L1)

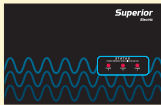

Phase indicator lights and Form "C" dry contacts for remote monitoring.

Advanced Diagnostic Monitoring (L3)

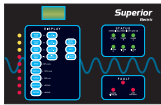

Phase indicator lights, LED numeric display, Form "C" dry contacts, audible alarm, alarm disable switch, alarm disabled indicator, alarm reset and test switches, phase and filter LED status indicators, real-time notification of % protection status, % protection warning, N-G voltage, N-G current, capacitor fuse status, RMS voltage, sags, surges, dropouts, outages, disturbance counter and non-volatile stored data.

TVSS Hand-Held Tester



TVSS-MT

Provides easy monitoring of Failure-Free Integrated Suppression Bus components: percentage of protection; phase, filter status; N-G voltages and currents. Battery operated.

Features & Benefits: • Economical and easy-to-use • Senses percentage of protection available • Monitors neutral-to-ground voltage and current

The TVSS Hand-Held Tester is an economical, hand-held device that performs off-line evaluation of Superior Electric's TVSS Series suppression filter systems and checks the neutral-to-ground integrity. TVSS Hand-Held Tester tests and reports these critical conditions and displays the results on its large LCD display.

Neutral-to-Ground Current Sensing: The RMS voltage measured across the neutral and ground alerts the operator of a possible neutral-to-ground bonding problem or asymmetrical load within the distribution system. Current detected on the ground conductor could indicate excessive leakage through the surge suppression device's neutral-to-ground path - a truer indication of neutral-to-ground voltage MOV degradation. TVSS Hand-Held Tester's neutral-to-ground voltage and ground current-sensing features are invaluable tools for monitoring the overall well-being of a distribution system.

# TVSS Type Number Designations

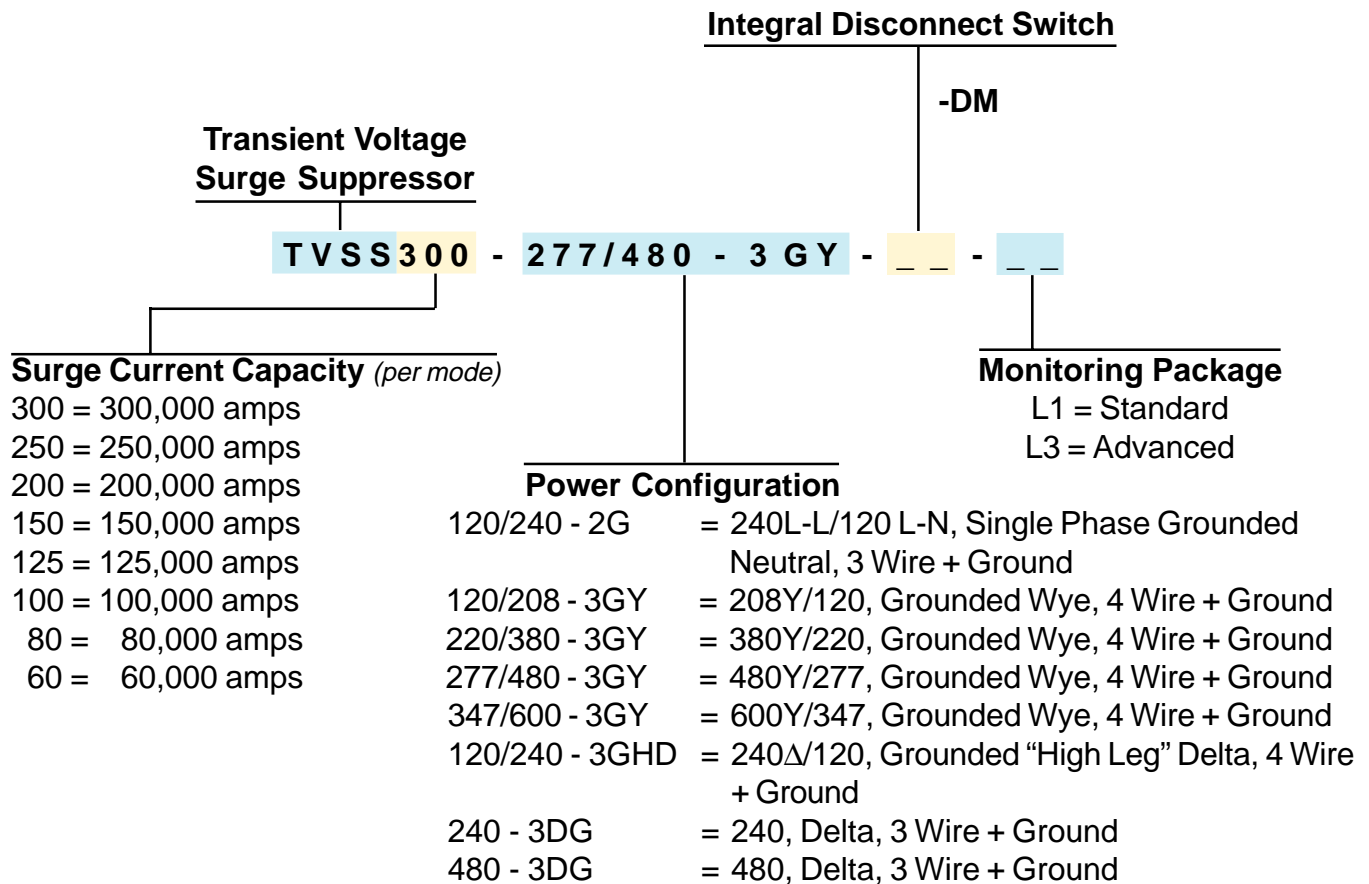

## TVSS Options Ordering Instructions

1. Choose base model. **Example: TVSS300-277/480-3GY**

2. Add option designation

- DM = Integral Disconnect Switch
- L1 = Standard Monitoring Package
- L3 = Advanced Monitoring Package

**Example: TVSS300-277/480-3GY-L1**

3. When ordering base model with Integral Disconnect Switch and Monitoring Package, add both option designations. **Example: TVSS300-277/480-3GY-DM-L3**

4. Order Hand-Held Tester as separate line item. **Example: TVSS-MT**

5. Contact the factory at 1-800-787-3532 or 860-585-4500 if you need assistance or have questions.

# TVSS300

300,000 amp surge current capacity

STABILINE®

## Advanced Electrical Transient Protection for Highest Exposure Applications



Metal Enclosure and Fiberglass Reinforced Polyester Enclosure

Standard TVSS300 Model Numbers
TVSS300-120/240-2G
TVSS300-120/208-3GY
TVSS300-220/380-3GY
TVSS300-277/480-3GY
TVSS300-347/600-3GY
TVSS300-120/240-3GHD
TVSS300-240-3DG
TVSS300-480-3DG

Contact factory for additional voltage configurations

Maximum Continuous Operating Voltage (MCOV)	
Voltage	MCOV
120V	150V
220V	275V
277V	320V
347V	420V
480V	640V
600V	840V

### Typical Clamping Voltage Data

System Voltage	Mode	B3 Ringwave	B3/C1 Comb. Wave	C3 Comb. Wave	UL 1449 Second Edition
120/240 120/208	L-N	325/375	425/450	650/775	400/400
	L-G	400/450	425/450	650/825	500/500
	N-G	350/350	475/475	750/750	500/500
	L-L	400/500	775/850	950/1250	700/700
277/480	L-N	550/600	875/900	1125/1225	800/800
	L-G	850/875	850/900	1075/1225	1000/1000
	N-G	700/700	900/900	1225/1225	800/900
	L-L	650/750	1650/1725	1950/2200	1500/1500

All suppression filter systems clamping voltages are in compliance with test and evaluation procedures outlined in NEMA LS 1-1992, paragraphs 2.2.10 and 3.10. Clamping voltage values shown without/with integral disconnect. Consult factory for voltage configurations not shown.

### Filtering Attenuation Frequencies

100KHz	1MHz	10MHz	100MHz
41dB	31dB	35dB	53dB

### Single/Repetitive Surge Current Capacities

Protection Mode	Single pulse surge current capacity/mode	Repetitive surge current capacity/mode
Line-to-Neutral	300,000 amps	7,500 impulses
Line-to-Ground	300,000 amps	7,500 impulses
Neutral-to-Ground	300,000 amps	7,500 impulses
Line-to-Line	300,000 amps	7,500 impulses
Per Phase	600,000 amps	N/A

In compliance with NEMA LS 1-1992, TVSS Series suppression filter systems are single pulse surge current tested in all modes at rated currents of the product by an industry-recognized independent test laboratory. Single pulse surge current capacities of 200,000 amps or less are established by single-unit testing of all components within each mode. Due to present industry test equipment limitations, single pulse surge current capacities over 200,000 amps are established via testing of individual components or sub-assemblies within a mode. Per ANSI/IEEE C62.41-1991 and ANSI/IEEE C62.45-1992, TVSS Series suppression filter systems are repetitive surge current capacity tested per mode utilizing a 1.2 x 50µsec 20KV open circuit voltage, 8 x 20 µsec 10 kA short circuit current Category C3 bi-wave at one minute intervals without suffering either performance degradation or more than 10% deviation of clamping voltage at a specified surge current.

### Mechanical Specifications

#### Dimensions:

Fiberglass Reinforced Polyester:  
19.5"H x 17.5"W x 9.5"D  
Metal: 28"H x 16"W x 9.5"D

#### Weight:

Fiberglass Reinforced Polyester: 57 lbs.  
Metal: 91 lbs.  
Enclosure type/mount: NEMA 4/12 surface  
Operating environment: -40°C to +60°C  
5% - 95% non-condensing humidity

### Electrical Specifications

Connection method: Parallel  
Protection Modes: L-N, L-G, N-G, L-L  
UL Listings: 1449-Second Edition  
1283  
UL Recognized: 248-1 (fuse)

# TVSS250

250,000 amp surge current capacity

STABILINE®

## Advanced Electrical Transient Protection for High Exposure Applications

Standard TVSS250 Model Numbers
TVSS250-120/240-2G
TVSS250-120/208-3GY
TVSS250-220/380-3GY
TVSS250-277/480-3GY
TVSS250-347/600-3GY
TVSS250-120/240-3GHD
TVSS250-240-3DG
TVSS250-480-3DG

Contact factory for additional voltage configurations

Maximum Continuous Operating Voltage (MCOV)	
Voltage	MCOV
120V	150V
220V	275V
277V	320V
347V	420V
480V	640V
600V	840V



Fiberglass Reinforced Polyester Enclosure and Metal Enclosure

### Typical Clamping Voltage Data

System Voltage	Mode	B3 Ringwave	B3/C1 Comb. Wave	C3 Comb. Wave	UL 1449 Second Edition
120/240	L-N	325/375	425/450	650/775	400/400
	L-G	400/450	425/450	650/825	500/500
	N-G	350/350	475/475	750/750	500/500
120/208	L-L	400/500	775/850	950/1250	700/700
	L-N	550/600	875/900	1125/1225	800/800
	L-G	850/875	850/900	1075/1225	1000/1000
277/480	N-G	700/700	900/900	1225/1225	800/900
	L-L	650/750	1650/1725	1950/2200	1500/1500

All suppression filter systems clamping voltages are in compliance with test and evaluation procedures outlined in NEMA LS 1-1992, paragraphs 2.2.10 and 3.10. Clamping voltage values shown without/with integral disconnect. Consult factory for voltage configurations not shown.

### Filtering Attenuation Frequencies

100KHz	1MHz	10MHz	100MHz
41dB	31dB	35dB	53dB

### Single/Repetitive Surge Current Capacities

Protection Mode	Single pulse surge current capacity/mode	Repetitive surge current capacity/mode
Line-to-Neutral	250,000 amps	7,000 impulses
Line-to-Ground	250,000 amps	7,000 impulses
Neutral-to-Ground	250,000 amps	7,000 impulses
Line-to-Line	250,000 amps	7,000 impulses
Per Phase	500,000 amps	N/A

In compliance with NEMA LS 1-1992, TVSS Series suppression filter systems are single pulse surge current tested in all modes at rated currents of the product by an industry-recognized independent test laboratory. Single pulse surge current capacities of 200,000 amps or less are established by single-unit testing of all components within each mode. Due to present industry test equipment limitations, single pulse surge current capacities over 200,000 amps are established via testing of individual components or sub-assemblies within a mode. Per ANSI/IEEE C62.41-1991 and ANSI/IEEE C62.45-1992, TVSS Series suppression filter systems are repetitive surge current capacity tested per mode utilizing a 1.2 x 50µsec 20KV open circuit voltage, 8 x 20 µsec 10 kA short circuit current Category C3 bi-wave at one minute intervals without suffering either performance degradation or more than 10% deviation of clamping voltage at a specified surge current.

### Mechanical Specifications

**Dimensions:**  
 Fiberglass Reinforced Polyester: 19.5"H x 17.5"W x 9.5"D  
 Metal: 28"H x 16"W x 9.5"D

**Weight:**  
 Fiberglass Reinforced Polyester: 57 lbs.  
 Metal: 91 lbs.  
 Enclosure type/mount: NEMA 4/12 surface  
 Operating environment: -40°C to +60°C  
 5% - 95% non-condensing humidity

### Electrical Specifications

Connection method: Parallel  
 Protection Modes: L-N, L-G, N-G, L-L  
 UL Listings: 1449-Second Edition  
 1283  
 UL Recognized: 248-1 (fuse)

# TVSS200

200,000 amp surge current capacity

STABILINE®

## Advanced Electrical Transient Protection for High to Medium Exposure Applications



Metal Enclosure and Fiberglass Reinforced Polyester Enclosure

Standard TVSS200 Model Numbers
TVSS200-120/240-2G
TVSS200-120/208-3GY
TVSS200-220/380-3GY
TVSS200-277/480-3GY
TVSS200-347/600-3GY
TVSS200-120/240-3GHD
TVSS200-240-3DG
TVSS200-480-3DG

Contact factory for additional voltage configurations

Maximum Continuous Operating Voltage (MCOV)	
Voltage	MCOV
120V	150V
220V	275V
277V	320V
347V	420V
480V	640V
600V	840V

### Typical Clamping Voltage Data

System Voltage	Mode	B3 Ringwave	B3/C1 Comb. Wave	C3 Comb. Wave	UL 1449 Second Edition
120/240	L-N	325/375	425/450	650/775	400/400
	L-G	400/450	425/450	650/825	500/500
120/208	N-G	350/350	475/475	750/750	500/500
	L-L	400/500	775/850	950/1250	700/700
277/480	L-N	550/600	875/900	1125/1225	800/800
	L-G	850/875	850/900	1075/1225	1000/1000
	N-G	700/700	900/900	1225/1225	800/900
	L-L	650/750	1650/1725	1950/2200	1500/1500

All suppression filter systems clamping voltages are in compliance with test and evaluation procedures outlined in NEMA LS 1-1992, paragraphs 2.2.10 and 3.10. Clamping voltage values shown without/with integral disconnect. Consult factory for voltage configurations not shown.

### Filtering Attenuation Frequencies

100KHz	1MHz	10MHz	100MHz
41dB	31dB	35dB	53dB

### Single/Repetitive Surge Current Capacities

Protection Mode	Single pulse surge current capacity/mode	Repetitive surge current capacity/mode
Line-to-Neutral	200,000 amps	6,500 impulses
Line-to-Ground	200,000 amps	6,500 impulses
Neutral-to-Ground	200,000 amps	6,500 impulses
Line-to-Line	200,000 amps	6,500 impulses
Per Phase	400,000 amps	N/A

In compliance with NEMA LS 1-1992, TVSS Series suppression filter systems are single pulse surge current tested in all modes at rated currents of the product by an industry-recognized independent test laboratory. Single pulse surge current capacities of 200,000 amps or less are established by single-unit testing of all components within each mode. Per ANSI/IEEE C62.41-1991 and ANSI/IEEE C62.45-1992, TVSS Series suppression filter systems are repetitive surge current capacity tested per mode utilizing a 1.2 x 50µsec 20KV open circuit voltage, 8 x 20 µsec 10 kA short circuit current Category C3 bi-wave at one minute intervals without suffering either performance degradation or more than 10% deviation of clamping voltage at a specified surge current.

### Mechanical Specifications

#### Dimensions:

Fiberglass Reinforced Polyester:  
19.5"H x 17.5"W x 9.5"D  
Metal: 28"H x 16"W x 9.5"D

#### Weight:

Fiberglass Reinforced Polyester: 57 lbs.  
Metal: 91 lbs.  
Enclosure type/mount: NEMA 4/12 surface  
Operating environment: -40°C to +60°C  
5% - 95% non-condensing humidity

### Electrical Specifications

Connection method: Parallel  
Protection Modes: L-N, L-G, N-G, L-L  
UL Listings: 1449-Second Edition  
1283  
UL Recognized: 248-1 (fuse)

# TVSS150

150,000 amp surge current capacity

STABILINE®

## Advanced Electrical Transient Protection for Medium Exposure Applications

Standard TVSS150 Model Numbers
TVSS150-120/240-2G
TVSS150-120/208-3GY
TVSS150-220/380-3GY
TVSS150-277/480-3GY
TVSS150-347/600-3GY
TVSS150-120/240-3GHD
TVSS150-240-3DG
TVSS150-480-3DG

Contact factory for additional voltage configurations

Maximum Continuous Operating Voltage (MCOV)	
Voltage	MCOV
120V	150V
220V	275V
277V	320V
347V	420V
480V	640V
600V	840V



Fiberglass Reinforced Polyester Enclosure and Metal Enclosure

### Typical Clamping Voltage Data

System Voltage	Mode	B3 Ringwave	B3/C1 Comb. Wave	C3 Comb. Wave	UL 1449 Second Edition
120/240 120/208	L-N	325/350	425/450	625/725	400/400
	L-G	400/450	425/475	625/750	500/500
	N-G	375/375	475/475	750/750	400/500
	L-L	375/475	775/850	975/1200	700/700
277/480	L-N	525/550	875/925	1150/1200	900/900
	L-G	850/875	850/875	1075/1175	1000/1000
	N-G	700/725	900/900	1200/1200	800/800
	L-L	675/725	1675/1725	1950/2175	1800/1500

All suppression filter systems clamping voltages are in compliance with test and evaluation procedures outlined in NEMA LS 1-1992, paragraphs 2.2.10 and 3.10. Clamping voltage values shown without/with integral disconnect. Consult factory for voltage configurations not shown.

Filtering Attenuation Frequencies			
100KHz	1MHz	10MHz	100MHz
44dB	33dB	36dB	53dB

Single/Repetitive Surge Current Capacities		
Protection Mode	Single pulse surge current capacity/mode	Repetitive surge current capacity/mode
Line-to-Neutral	150,000 amps	5,500 impulses
Line-to-Ground	150,000 amps	5,500 impulses
Neutral-to-Ground	150,000 amps	5,500 impulses
Line-to-Line	150,000 amps	5,500 impulses
Per Phase	300,000 amps	N/A

In compliance with NEMA LS 1-1992, TVSS Series suppression filter systems are single pulse surge current tested in all modes at rated currents of the product by an industry-recognized independent test laboratory. Single pulse surge current capacities of 200,000 amps or less are established by single-unit testing of all components within each mode. Per ANSI/IEEE C62.41-1991 and ANSI/IEEE C62.45-1992, TVSS Series suppression filter systems are repetitive surge current capacity tested per mode utilizing a 1.2 x 50µsec 20KV open circuit voltage, 8 x 20 µsec 10 kA short circuit current Category C3 bi-wave at one minute intervals without suffering either performance degradation or more than 10% deviation of clamping voltage at a specified surge current.

Mechanical Specifications
<b>Dimensions:</b> Fiberglass Reinforced Polyester: 17.5"H x 15.5"W x 7"D Metal: 20"H x 16"W x 9.5"D
<b>Weight:</b> Fiberglass Reinforced Polyester: 57 lbs. Metal: 59 lbs. Enclosure type/mount: NEMA 4/12 surface Operating environment: -40°C to +60°C 5% - 95% non-condensing humidity

Electrical Specifications
Connection method: Parallel Protection Modes: L-N, L-G, N-G, L-L UL Listings: 1449-Second Edition 1283 UL Recognized: 248-1 (fuse)

# TVSS125

125,000 amp surge current capacity

STABILINE®

## Advanced Electrical Transient Protection for Medium Exposure Applications



Metal Enclosure and Fiberglass Reinforced Polyester Enclosure

Standard TVSS125 Model Numbers
TVSS125-120/240-2G
TVSS125-120/208-3GY
TVSS125-220/380-3GY
TVSS125-277/480-3GY
TVSS125-347/600-3GY
TVSS125-120/240-3GHD
TVSS125-240-3DG
TVSS125-480-3DG

Contact factory for additional voltage configurations

Maximum Continuous Operating Voltage (MCOV)	
Voltage	MCOV
120V	150V
220V	275V
277V	320V
347V	420V
480V	640V
600V	840V

### Typical Clamping Voltage Data

System Voltage	Mode	B3 Ringwave	B3/C1 Comb. Wave	C3 Comb. Wave	UL 1449 Second Edition
120/240	L-N	325/350	425/450	625/725	400/400
	L-G	400/450	425/475	625/750	500/500
120/208	N-G	375/375	475/475	750/750	400/500
	L-L	375/475	775/850	975/1200	700/700
277/480	L-N	525/550	875/925	1150/1200	900/900
	L-G	850/875	850/875	1075/1175	1000/1000
	N-G	700/725	900/900	1200/1200	800/800
	L-L	675/725	1675/1725	1950/2175	1800/1500

All suppression filter systems clamping voltages are in compliance with test and evaluation procedures outlined in NEMA LS 1-1992, paragraphs 2.2.10 and 3.10. Clamping voltage values shown without/with integral disconnect. Consult factory for voltage configurations not shown.

Filtering Attenuation Frequencies			
100KHz	1MHz	10MHz	100MHz
44dB	33dB	36dB	53dB

Single/Repetitive Surge Current Capacities		
Protection Mode	Single pulse surge current capacity/mode	Repetitive surge current capacity/mode
Line-to-Neutral	125,000 amps	5,000 impulses
Line-to-Ground	125,000 amps	5,000 impulses
Neutral-to-Ground	125,000 amps	5,000 impulses
Line-to-Line	125,000 amps	5,000 impulses
Per Phase	250,000 amps	N/A

In compliance with NEMA LS 1-1992, TVSS Series suppression filter systems are single pulse surge current tested in all modes at rated currents of the product by an industry-recognized independent test laboratory. Single pulse surge current capacities of 200,000 amps or less are established by single-unit testing of all components within each mode. Per ANSI/IEEE C62.41-1991 and ANSI/IEEE C62.45-1992, TVSS Series suppression filter systems are repetitive surge current capacity tested per mode utilizing a 1.2 x 50µsec 20KV open circuit voltage, 8 x 20 µsec 10 kA short circuit current Category C3 bi-wave at one minute intervals without suffering either performance degradation or more than 10% deviation of clamping voltage at a specified surge current.

Mechanical Specifications
<b>Dimensions:</b> Fiberglass Reinforced Polyester: 17.5"H x 15.5"W x 7"D Metal: 20"H x 16"W x 9.5"D
<b>Weight:</b> Fiberglass Reinforced Polyester: 57 lbs. Metal: 59 lbs. Enclosure type/mount: NEMA 4/12 surface Operating environment: -40°C to +60°C 5% - 95% non-condensing humidity

Electrical Specifications
Connection method: Parallel Protection Modes: L-N, L-G, N-G, L-L UL Listings: 1449-Second Edition 1283 UL Recognized: 248-1 (fuse)

# TVSS100

100,000 amp surge current capacity

STABILINE®

## Advanced Electrical Transient Protection for Medium to Low Exposure Applications

Standard TVSS100 Model Numbers
TVSS100-120/240-2G
TVSS100-120/208-3GY
TVSS100-220/380-3GY
TVSS100-277/480-3GY
TVSS100-347/600-3GY
TVSS100-120/240-3GHD
TVSS100-240-3DG
TVSS100-480-3DG

Contact factory for additional voltage configurations

Maximum Continuous Operating Voltage (MCOV)	
Voltage	MCOV
120V	150V
220V	275V
277V	320V
347V	420V
480V	640V
600V	840V



Fiberglass Reinforced Polyester Enclosure and Metal Enclosure

### Typical Clamping Voltage Data

System Voltage	Mode	B3 Ringwave	B3/C1 Comb. Wave	C3 Comb. Wave	UL 1449 Second Edition
120/240 120/208	L-N	325/350	425/450	625/725	400/400
	L-G	400/450	425/475	625/750	500/500
	N-G	375/375	475/475	750/750	400/500
	L-L	375/475	775/850	975/1200	700/700
277/480	L-N	525/550	875/925	1150/1200	900/900
	L-G	850/875	850/875	1075/1175	1000/1000
	N-G	700/725	900/900	1200/1200	800/800
	L-L	675/725	1675/1725	1950/2175	1800/1500

All suppression filter systems clamping voltages are in compliance with test and evaluation procedures outlined in NEMA LS 1-1992, paragraphs 2.2.10 and 3.10. Clamping voltage values shown without/with integral disconnect. Consult factory for voltage configurations not shown.

Filtering Attenuation Frequencies			
100KHz	1MHz	10MHz	100MHz
44dB	33dB	36dB	53dB

Single/Repetitive Surge Current Capacities		
Protection Mode	Single pulse surge current capacity/mode	Repetitive surge current capacity/mode
Line-to-Neutral	100,000 amps	4,500 impulses
Line-to-Ground	100,000 amps	4,500 impulses
Neutral-to-Ground	100,000 amps	4,500 impulses
Line-to-Line	100,000 amps	4,500 impulses
Per Phase	200,000 amps	N/A

In compliance with NEMA LS 1-1992, TVSS Series suppression filter systems are single pulse surge current tested in all modes at rated currents of the product by an industry-recognized independent test laboratory. Single pulse surge current capacities of 200,000 amps or less are established by single-unit testing of all components within each mode. Per ANSI/IEEE C62.41-1991 and ANSI/IEEE C62.45-1992, TVSS Series suppression filter systems are repetitive surge current capacity tested per mode utilizing a 1.2 x 50µsec 20KV open circuit voltage, 8 x 20 µsec 10 kA short circuit current Category C3 bi-wave at one minute intervals without suffering either performance degradation or more than 10% deviation of clamping voltage at a specified surge current.

Mechanical Specifications
<b>Dimensions:</b> Fiberglass Reinforced Polyester: 17.5"H x 15.5"W x 7"D Metal: 20"H x 16"W x 9.5"D
<b>Weight:</b> Fiberglass Reinforced Polyester: 57 lbs. Metal: 59 lbs. Enclosure type/mount: NEMA 4/12 surface Operating environment: -40°C to +60°C 5% - 95% non-condensing humidity

Electrical Specifications
Connection method: Parallel Protection Modes: L-N, L-G, N-G, L-L UL Listings: 1449-Second Edition 1283 UL Recognized: 248-1 (fuse)

## Advanced Electrical Transient Protection for Low Exposure Applications



Metal Enclosure and Fiberglass Reinforced Polyester Enclosure

Standard TVSS80 Model Numbers
TVSS80-120/240-2G
TVSS80-120/208-3GY
TVSS80-220/380-3GY
TVSS80-277/480-3GY
TVSS80-347/600-3GY
TVSS80-120/240-3GHD
TVSS80-240-3DG
TVSS80-480-3DG

Contact factory for additional voltage configurations

Maximum Continuous Operating Voltage (MCOV)	
Voltage	MCOV
120V	150V
220V	275V
277V	320V
347V	420V
480V	640V
600V	840V

### Typical Clamping Voltage Data

System Voltage	Mode	B3 Ringwave	B3/C1 Comb. Wave	C3 Comb. Wave	UL 1449 Second Edition
120/240 120/208	L-N	300/325	400/425	550/700	400/400
	L-G	400/425	400/450	600/750	500/500
	N-G	325/350	475/475	800/800	500/500
	L-L	425/475	725/800	900/1125	700/700
277/480	L-N	500/525	875/900	1050/1175	900/900
	L-G	825/875	825/875	1025/1150	1000/1000
	N-G	650/650	875/900	1200/1225	800/900
	L-L	700/775	1625/1675	1825/2025	1800/1800

All suppression filter systems clamping voltages are in compliance with test and evaluation procedures outlined in NEMA LS 1-1992, paragraphs 2.2.10 and 3.10. Clamping voltage values shown without/with integral disconnect. Consult factory for voltage configurations not shown.

### Filtering Attenuation Frequencies

100KHz	1MHz	10MHz	100MHz
50dB	37dB	38dB	53dB

### Single/Repetitive Surge Current Capacities

Protection Mode	Single pulse surge current capacity/mode	Repetitive surge current capacity/mode
Line-to-Neutral	80,000 amps	4,000 impulses
Line-to-Ground	80,000 amps	4,000 impulses
Neutral-to-Ground	80,000 amps	4,000 impulses
Line-to-Line	80,000 amps	4,000 impulses
Per Phase	160,000 amps	N/A

In compliance with NEMA LS 1-1992, TVSS Series suppression filter systems are single pulse surge current tested in all modes at rated currents of the product by an industry-recognized independent test laboratory. Single pulse surge current capacities of 200,000 amps or less are established by single-unit testing of all components within each mode. Per ANSI/IEEE C62.41-1991 and ANSI/IEEE C62.45-1992, TVSS Series suppression filter systems are repetitive surge current capacity tested per mode utilizing a 1.2 x 50µsec 20KV open circuit voltage, 8 x 20 µsec 10 kA short circuit current Category C3 bi-wave at one minute intervals without suffering either performance degradation or more than 10% deviation of clamping voltage at a specified surge current.

### Mechanical Specifications

#### Dimensions:

Fiberglass Reinforced Polyester:  
15.5"H x 13.5"W x 7"D  
Metal: 16"H x 16"W x 9.5"D

#### Weight:

Fiberglass Reinforced Polyester: 57 lbs.  
Metal: 45 lbs.  
Enclosure type/mount: NEMA 4/12 surface  
Operating environment: -40°C to +60°C  
5% - 95% non-condensing humidity

### Electrical Specifications

Connection method: Parallel  
Protection Modes: L-N, L-G, N-G, L-L  
UL Listings: 1449-Second Edition  
1283  
UL Recognized: 248-1 (fuse)

# TVSS60

60,000 amp surge current capacity

STABILINE®

## Advanced Electrical Transient Protection for Lowest Exposure Applications

Standard TVSS60 Model Numbers
TVSS60-120/240-2G
TVSS60-120/208-3GY
TVSS60-220/380-3GY
TVSS60-277/480-3GY
TVSS60-347/600-3GY
TVSS60-120/240-3GHD
TVSS60-240-3DG
TVSS60-480-3DG

Contact factory for additional voltage configurations

Maximum Continuous Operating Voltage (MCOV)	
Voltage	MCOV
120V	150V
220V	275V
277V	320V
347V	420V
480V	640V
600V	840V



Fiberglass Reinforced Polyester Enclosure and Metal Enclosure

### Typical Clamping Voltage Data

System Voltage	Mode	B3 Ringwave	B3/C1 Comb. Wave	C3 Comb. Wave	UL 1449 Second Edition
120/240 120/208	L-N	300/325	400/425	550/700	400/400
	L-G	400/425	400/450	600/750	500/500
	N-G	325/350	475/475	800/800	500/500
	L-L	425/475	725/800	900/1125	700/700
277/480	L-N	500/525	875/900	1050/1175	900/900
	L-G	825/875	825/875	1025/1150	1000/1000
	N-G	650/650	875/900	1200/1225	800/900
	L-L	700/775	1625/1675	1825/2025	1800/1800

All suppression filter systems clamping voltages are in compliance with test and evaluation procedures outlined in NEMA LS 1-1992, paragraphs 2.2.10 and 3.10. Clamping voltage values shown without/with integral disconnect. Consult factory for voltage configurations not shown.

Filtering Attenuation Frequencies			
100KHz	1MHz	10MHz	100MHz
50dB	37dB	38dB	53dB

Single/Repetitive Surge Current Capacities		
Protection Mode	Single pulse surge current capacity/mode	Repetitive surge current capacity/mode
Line-to-Neutral	60,000 amps	3,500 impulses
Line-to-Ground	60,000 amps	3,500 impulses
Neutral-to-Ground	60,000 amps	3,500 impulses
Line-to-Line	60,000 amps	3,500 impulses
Per Phase	120,000 amps	N/A

In compliance with NEMA LS 1-1992, TVSS Series suppression filter systems are single pulse surge current tested in all modes at rated currents of the product by an industry-recognized independent test laboratory. Single pulse surge current capacities of 200,000 amps or less are established by single-unit testing of all components within each mode. Per ANSI/IEEE C62.41-1991 and ANSI/IEEE C62.45-1992, TVSS Series suppression filter systems are repetitive surge current capacity tested per mode utilizing a 1.2 x 50µsec 20KV open circuit voltage, 8 x 20 µsec 10 kA short circuit current Category C3 bi-wave at one minute intervals without suffering either performance degradation or more than 10% deviation of clamping voltage at a specified surge current.

Mechanical Specifications
<b>Dimensions:</b> Fiberglass Reinforced Polyester: 15.5"H x 13.5"W x 7"D Metal: 16"H x 16"W x 9.5"D
<b>Weight:</b> Fiberglass Reinforced Polyester: 57 lbs. Metal: 45 lbs. Enclosure type/mount: NEMA 4/12 surface Operating environment: -40°C to +60°C 5% - 95% non-condensing humidity

Electrical Specifications
Connection method: Parallel Protection Modes: L-N, L-G, N-G, L-L UL Listings: 1449-Second Edition 1283 UL Recognized: 248-1 (fuse)

# TVSS Hand-Held Tester

## For TVSS Series STABILINE® Transient Voltage Surge Suppressors

### Features and Benefits

- Economical and easy-to-use
- Senses percentage of protection available
- Monitors neutral-to-ground voltage and ground current
- Checks RFI/EMI filter capacitors

The STABILINE® TVSS Hand-Held Tester is an economical device that performs off-line evaluation of the TVSS Series STABILINE suppression filter system and helps validate neutral-to-ground integrity. The TVSS Hand-Held Tester monitors and reports these critical conditions and displays the results on its large LCD display:

**% Protection Available Sensing:** The TVSS Hand-Held Tester displays the available surge protection for each phase. With microprocessor-based circuitry, the TVSS Hand-Held Tester senses each hybrid element fuse; calculates the amount of protection still active in the circuit; and displays this value as a percentage of total protection. This capability assures the operator that critical loads are fully and safely protected with a failure-free device. Unlike passive monitoring systems that provide “all or nothing” post-event data, the TVSS Hand-Held Tester displays the percent of protection so that the operator knows the true status of the suppression filter system. This feature monitors the status of the MOVs and filter capacitors.



TVSS-MT

**Neutral-to-Ground Voltage and Current Sensing:** The RMS voltage measured across the neutral and ground alerts the operator of a possible neutral-to-ground bonding problem or asymmetrical load within the distribution system. Current detected on the TVSS' ground conductor could indicate excessive leakage through the neutral-to-ground path — a truer indication of neutral-to-ground MOV degradation. The TVSS Hand-Held Tester's neutral-to-ground voltage and ground current sensing features are invaluable tools for monitoring the overall well-being of a distribution system.

# Superior Electric

*brings you a*

## SINGLE SOURCE

*for*

### Voltage Control

&

### Power Protection Products



5-WAY®/SUPERCON®  
Binding Posts • Electrical Connectors



### STABILINE®

Uninterruptible Power Supplies • Power Conditioners  
• Voltage Regulators • Transient Voltage Surge Suppressors



### POWERSTAT®

Variable Transformers

# Distribution Coast-To-Coast and International

TVSS Series STABILINE® Transient Voltage Surge Suppression products are obtainable worldwide through an extensive authorized distributor network. These distributors offer literature and technical assistance.

In addition, Superior Electric sales engineers are available to provide prompt attention to customer needs. Call or fax for ordering and application information or for the address of the closest authorized distributor. Visit our Web Site at: [www.superiorelectric.com](http://www.superiorelectric.com) for more information.

---

## Worldwide

383 Middle Street • Bristol, CT 06010  
Tel: 860-585-4500 • Fax: 860-582-3784

## In U.S.A. and Canada

Customer Service: 1-800-787-3532 - Ext. 4750  
Product Application: 1-800-787-3532 - Ext. 4755  
Product Literature Request: 1-800-787-3532 - Ext. 4750  
Fax: 1-800-821-1369

---

### Superior Electric

**SLO-SYN**® Step/Servo Motors and Controls  
**POWERSTAT**® Variable Transformers  
**SUPERCON**® Electrical Connectors

**LUXTROL**® Lighting Controls  
**STABILINE**® Power Protection Products  
**5-WAY**® Binding Posts

---

### Seco AC/DC Drives

**BRONCO**® AC and DC Drives  
**NEXTDRIVE**™ Adjustable Frequency Drives  
**SV3000** Flux Vector AC Drives

**SECO**® Adjustable Speed Drives  
**M4000** DC Adjustable Speed Drives

---

### Danaher Motion Engineered Systems Center

Integrator of **Seco AC/DC Drives**, and **Warner Linear** components as well as components of other manufacturers into complete motion control/drive system solutions.

---

Web Site: [www.superiorelectric.com](http://www.superiorelectric.com)

**Superior**  
**Electric**

383 Middle Street • Bristol, CT 06010 USA  
Tel: 860.585.4500 • Fax: 860.582.3784