

TM 314 – TM 317

In-Line Torque Transducers

FEATURES

- Integrated Torque and Speed Conditioning
- Torque Rating: 1000 to 10,000 N·m (737 to 7375 lb-ft)
- Accuracy: < 0.1% (depending on model)
- Overload Capacity: 200%
- Overload Limit: 500% (TM 317 up to 350%)
- High Speed Applications: up to 16,000 rpm
- Non-Contact (no slippings)
- No Electronic Components in Rotation
- High Electrical Noise Immunity
- Single DC Power Supply: 20 VDC to 32 VDC
- Immediate Speed Detection
- Adjustable Torque Signal Frequency Limitation
- Built-in Test Function
- Stainless Steel Shaft
- EMC Susceptibility Conforms to European Standards

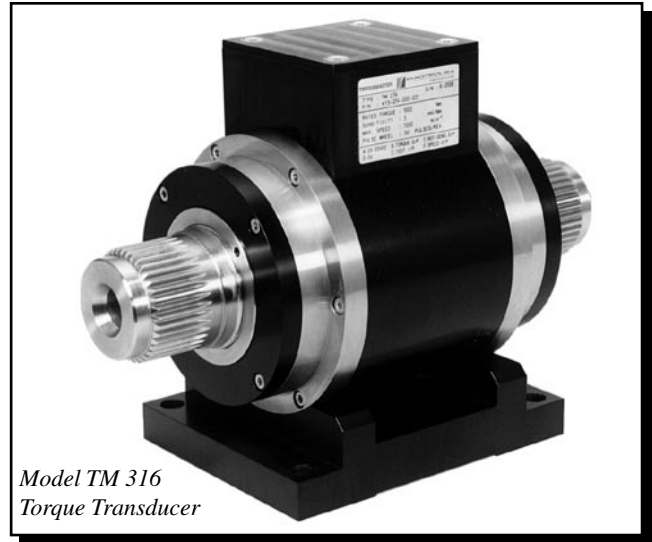

DESCRIPTION

Magtrol's In-Line Torque Transducers provide extremely accurate torque and speed measurement over a very broad range. Each model has an integrated conditioning electronic module providing a 0 to ± 10 VDC torque output and an open collector speed output. Magtrol Torque Transducers are very reliable, providing high overload protection, excellent long term stability and high noise immunity.

All transducer models employ our unique non-contact differential transformer torque measuring technology. This measuring technology offers many benefits, most notably that no electronic components rotate during operation.

To provide customers with several price/performance options, Magtrol offers two torque transducer models: high accuracy (TM series) and high speed with high accuracy (TMHS).

Each transducer consists of a hardened stainless steel shaft with smooth or splined shaft ends, an anodized aluminium housing containing the guide bearings and an electronic measurement conditioner. The integrated electronic circuit,

supplied by single DC voltage, provides torque and speed signals without any additional amplifier. The transducer is a stand-alone measuring chain. Connections are made by means of a 6-pole male connector mounted on the housing. A removable aluminium base, delivered as standard, allows fixed mounting of the transducer.

APPLICATIONS

TM and TMHS Series Torque Transducers provide dynamic torque and speed measurement of:

- Propellers - aerospace, marine and helicopter
- Windshield wipers, electrical windows, starters, generators and brakes in automobile industry
- Pumps - water and oil
- Reduction gears and gearboxes
- Clutches
- Motorized valves
- Drills, pneumatic tools and other machine tools

BASIC SYSTEM CONFIGURATION

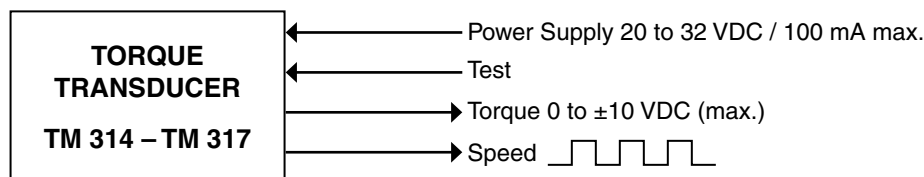



MODEL RATINGS

The ratings in the following table apply to both Torque Transducer series (TM and TMHS).

Model	Nominal Rated Torque		Torsional Stiffness		Shaft Ends	Moment of Inertia		Weight	
	N-m	lb-ft	N-m/rad	lb-ft/rad		kg-m ²	lb-ft-s ²	kg	lb
314	1,000	737	3.28 × 10 ⁵	2.41 × 10 ⁵	keyway	3.00 × 10 ⁻³	2.24 × 10 ⁻³	9.9	21.8
					splined	2.76 × 10 ⁻³	2.04 × 10 ⁻³	9.2	20.3
315	2,000	1,475	6.56 × 10 ⁵	4.83 × 10 ⁵	keyway	3.29 × 10 ⁻³	2.43 × 10 ⁻³	10.8	23.8
					splined	3.01 × 10 ⁻³	2.22 × 10 ⁻³	10.1	22.3
316	5,000	3,687	1.94 × 10 ⁶	1.43 × 10 ⁶	splined	9.93 × 10 ⁻³	7.32 × 10 ⁻³	20.0	44.1
317	10,000	7,375	2.95 × 10 ⁶	2.17 × 10 ⁶	splined	1.17 × 10 ⁻²	8.62 × 10 ⁻³	22.3	49.2

SERIES RATINGS

The ratings in the following table apply to all standard Torque Transducer models 314–317.

Standard Version	Model	TM Series	TMHS Series
TORQUE MEASUREMENT			
Rated Torque (RT)	314–317	0 to ±100% of RT	
Maximum Dynamic Torque Peak Value (Overload Capacity)	314–317	0 to ±200% of RT	
Maximum Dynamic Torque Without Damage (Overload Limit)	314–316	0 to ±500% of RT	
	317	0 to ±350% of RT	
Combined Error of Linearity and Hysteresis to 100% of RT	314–316	< ±0.1% of RT	
	317	< ±0.15% of RT	
Combined Error of Linearity and Hysteresis from 100 to 200% of RT	314–316	< ±0.1% of measured value	
	317	< ±0.15% of measured value	
Temperature Influence on the Zero/Sensitivity: • In the Compensated Range +10 °C to +60 °C • In the Compensated Range -25 °C to +80 °C	314–317	< ±0.1% of RT/10K < ±0.2% of RT/10K	
Influence of Speed on the Zero Torque Signal	314–317	< ±0.01% of RT/1000 rpm	
Long-term Stability of Sensitivity	314–317	< ±0.05% of RT/year	
SPEED MEASUREMENT			
Rated Range of Use	314–315	1 to 7,000 rpm	1 to 16,000 rpm
	316–317	1 to 5,000 rpm	1 to 12,000 rpm
Number of Teeth	314–317	60 Z	
Minimum Speed Detection	314–317	1 rpm	
ENVIRONMENT			
Storage Temperature Range	314–317	-40 °C to +100 °C	
Operating Temperature Range	314–317	-40 °C to +85 °C	
Mechanical Shock	314–317	according to IEC 68.2.27 / Class D3	
Vibration	314–317	according to IEC 68.2.6 / Class D3	
Protection Class	314–317	IP 44	
MECHANICAL CHARACTERISTICS			
Shaft Ends	314–315	splined or keyway	
	316–317	splined	
Balancing Quality	314–317	G1 according to ISO 1940	
Foot Support (Base Mount)	314–317	included	
INPUT AND OUTPUT SIGNALS			
Power Supply (max. voltage / current)	314–317	20 to 32 VDC / 100 mA	
Torque Output (rated / max.)	314–317	±5 / ±10 VDC	
Filter Cutoff (frequency)	314–317	5000, 2500, 1000, 500, 200, 100, 40, 20, 10, 5, 2, 1 Hz	
Speed Output (frequency)	314–317	open collector (15 Ω in series), max. 30 VDC, protected against short-circuits	
CONNECTORS			
Counter Connector (female)	314–317	optional (P/N 957.11.08.0081)	

OPERATING PRINCIPLES

The measuring system, based on the principle of a variable, torque-proportional transformer coupling, consists of two concentric cylinders shrunk on the shaft on each side of the shaft's deformation zone, and two concentric coils attached to the housing.

Both cylinders have a circularly disposed coinciding row of slots and rotate with the shaft inside the coils. An alternating current with the frequency of 20 kHz flows through the primary coil. When no torque is applied, the slots on the two cylinders fail to overlap. When torque is applied, the deformation zone undergoes an angular deformation and the slots begin to overlap.

Thus a torque-proportional voltage is on the secondary coil. The conditioning electronic circuit incorporated in the transducer converts the voltage to a nominal torque signal of 0 to ±5 VDC. A low-pass filter (Butterworth/2nd order), adjustable from 5 kHz to 1 Hz, allows tuning of the torque signal frequency limitation.

An optical sensor reads the speed on a toothed path machined directly on the measuring system. The electronic conditioner outputs a frequency signal proportional to the shaft rotational speed. An active circuit compensates the zero and sensitivity temperature drifts within a tolerance of 0.1% / 10 K.

TM and TMHS Transducers with Keyway Shaft

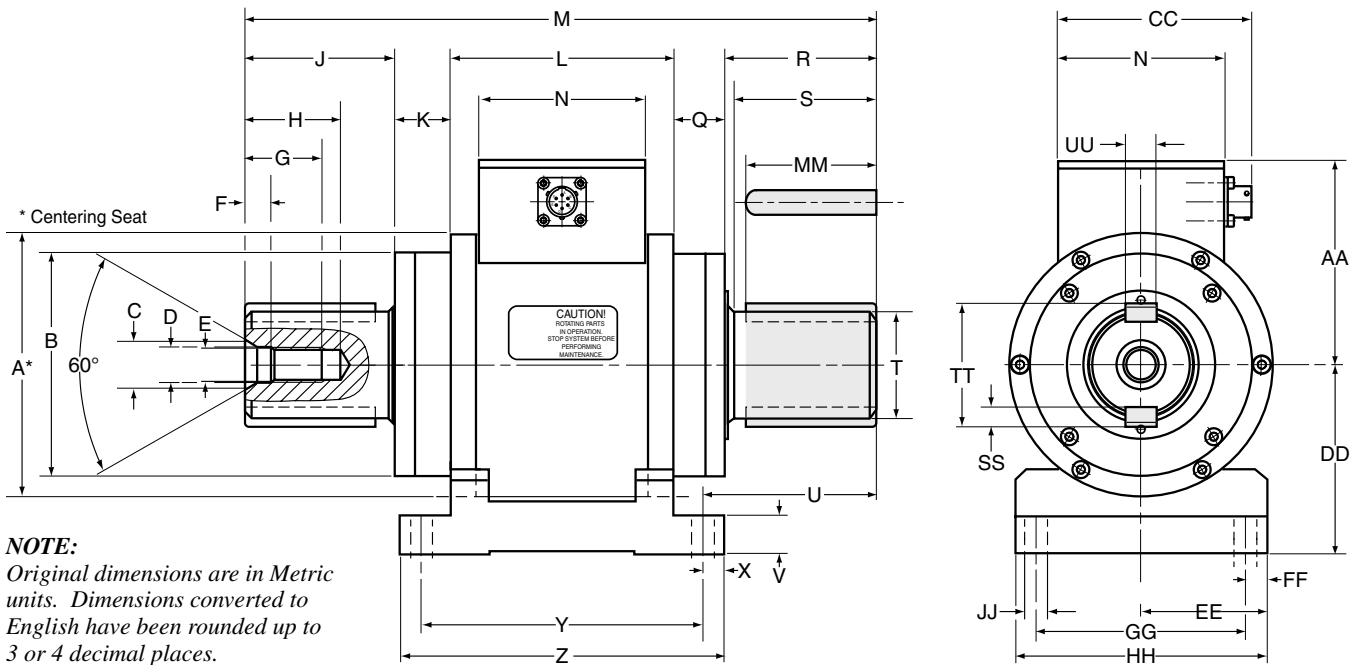

NOTE:
Original dimensions are in Metric units. Dimensions converted to English have been rounded up to 3 or 4 decimal places.

Model*	units	Ø A	Ø B	Ø C	Ø D	E	F	G	H	J	K	L	M	N	Q	R	S	Ø T	U
314/X31	mm	125g6	106	23	17	M16	12	36	45	67.7	26.8	106	294	80	25	68.5	65	50h6	79.5
	in	4.9207 4.9197	4.173	0.906	0.669	M16	0.472	1.417	1.772	2.665	1.055	4.173	11.575	3.150	0.984	2.697	2.559	1.9685 1.9679	3.130
315/X31	mm	125g6	106	23	17	M16	12	36	45	87.7	26.8	106	334	80	25	88.5	85	50h6	99.5
	in	4.9207 4.9197	4.173	0.906	0.669	M16	0.472	1.417	1.772	3.453	1.055	4.173	13.150	3.150	0.984	3.484	3.346	1.9685 1.9679	3.917

Model*	units	V	X	Y	Z	AA	CC	DD	EE	FF	GG	HH	Ø JJ	MM	SS	TT	UU
314/X31	mm	18	10	134	154	98	93	90±0.025	60±0.025	10	100	120±0.05	11	60.0	9h11	57	14h9
	in	0.709	0.394	5.276	6.063	3.858	3.661	3.5443 3.5423	2.3632 2.3612	0.394	3.937	4.7264 4.7224	0.433	2.362	0.3543 0.3508	2.244	0.5512 0.5495
315/X31	mm	18	10	134	154	98	93	90±0.025	60±0.025	10	100	120±0.05	11	59.7	9h11	57	14h9
	in	0.709	0.394	5.276	6.063	3.858	3.661	3.5443 3.5423	2.3632 2.3612	0.394	3.937	4.7264 4.7224	0.433	2.350	0.3543 0.3508	2.244	0.5512 0.5495

* A TM Series Torque Transducer with keyway shaft is indicated by the suffix /031.
A TMHS Series Torque Transducer with keyway shaft is indicated by the suffix /131.

TM and TMHS Transducers with Splined Shaft

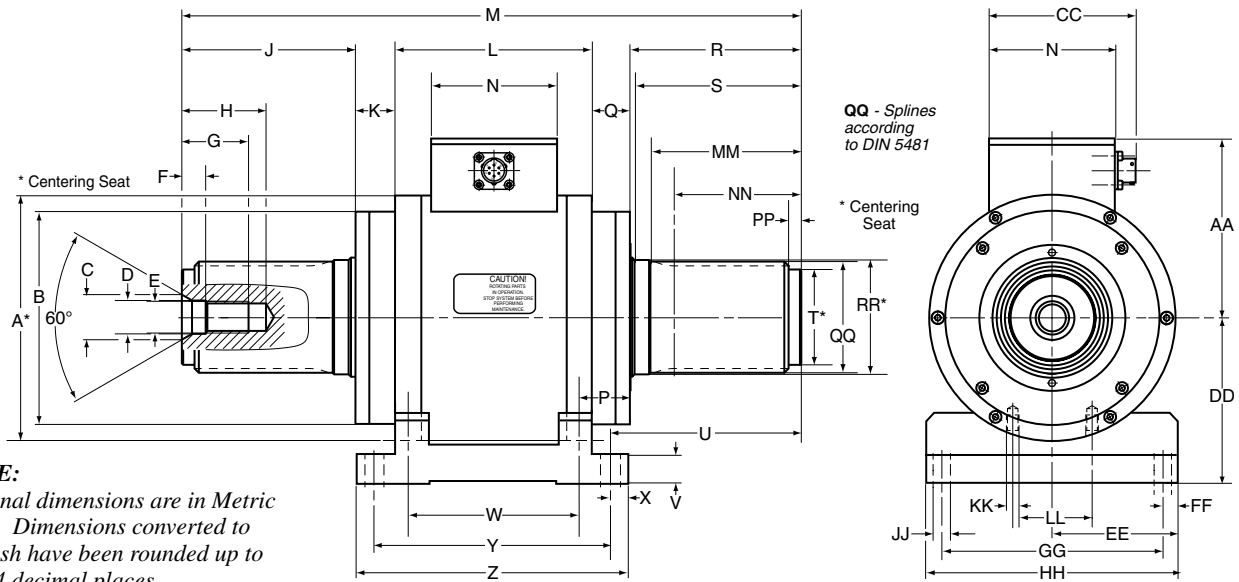

NOTE:
Original dimensions are in Metric units. Dimensions converted to English have been rounded up to 3 or 4 decimal places.

Model*	units	Ø A	Ø B	Ø C	Ø D	E	F	G	H	J	K	L	M	N	P	Q	R	S	Ø T	U	V
314/X21	mm	125g6	106	23	17	M16	12	36	45	50.7	26.8	106	260	80	32	25	51.5	48	44h6	62.5	18
	in	4.9207 4.9197	4.173	0.906	0.669	M16	0.472	1.417	1.772	1.996	1.055	4.173	10.236	3.150	1.260	0.984	2.028	1.890	1.7323 1.7317	2.461	0.709
315/X21	mm	125g6	106	23	17	M16	12	36	45	70.7	26.8	106	300	80	32	25	71.5	68	44h6	82.5	18
	in	4.9207 4.9197	4.173	0.906	0.669	M16	0.472	1.417	1.772	2.784	1.055	4.173	11.811	3.150	1.260	0.984	2.815	2.677	1.7323 1.7317	3.248	0.709
316/X21	mm	155g6	135	28.4	21	M20	15	42	53	82.7	25.8	124	340	80	33	24	83.5	80	55h6	94.5	18
	in	6.1018 6.1008	5.315	1.118	0.827	M20	0.591	1.654	2.087	3.256	1.016	4.882	13.386	3.150	1.299	0.945	3.287	3.150	2.1654 2.1646	3.721	0.709
317/X21	mm	155g6	135	28.4	21	M20	15	42	53	107.7	25.8	124	390	80	33	24	108.5	105	60h6	119.5	18
	in	6.1018 6.1008	5.315	1.118	0.827	M20	0.591	1.654	2.087	4.240	1.016	4.882	15.354	3.150	1.299	0.945	4.272	4.134	2.3622 2.3615	4.705	0.709

Model*	units	W	X	Y	Z	AA	CC	DD	EE	FF	GG	HH	Ø JJ	KK	LL	MM	NN	PP	QQ	Ø RR
314/X21	mm	92	10	134	154	98	93	90±0.025	60±0.025	10	100	120±0.05	11	M8×10	36	42	28	8	45×50	52h6
	in	3.622	0.394	5.276	6.063	3.858	3.661	3.5443 3.5423	2.3632 2.3612	0.394	3.937	4.7264 4.7224	0.433	M8× 0.394	1.417	1.654	1.102	0.315	45×50	2.0472 2.0465
315/X21	mm	92	10	134	154	98	93	90±0.025	60±0.025	10	100	120±0.05	11	M8×10	36	62	48	8	45×50	52h6
	in	3.622	0.394	5.276	6.063	3.858	3.661	3.5443 3.5423	2.3632 2.3612	0.394	3.937	4.7264 4.7224	0.433	M8× 0.394	1.417	2.441	1.890	0.315	45×50	2.0472 2.0465
316/X21	mm	106	10	150	170	113.5	93	105±0.025	80±0.025	10	140	160±0.05	11	M8×10	50	70	50	8	60×65	70h6
	in	4.173	0.394	5.905	6.693	4.468	3.661	4.1348 4.1329	3.1506 3.1486	0.394	5.512	6.3012 6.2972	0.433	M8× 0.394	1.968	2.756	1.968	0.315	60×65	2.7559 2.7552
317/X21	mm	106	10	150	170	113.5	93	105±0.025	80±0.025	10	140	160±0.05	11	M8×10	50	95	80	8	65×70	72h6
	in	4.173	0.394	5.905	6.693	4.468	3.661	4.1348 4.1329	3.1506 3.1486	0.394	5.512	6.3012 6.2972	0.433	M8× 0.394	1.968	3.740	3.150	0.315	65×70	2.8346 2.8339

* A TM Series Torque Transducer with splined shaft is indicated by the suffix /021.
A TMHS Series Torque Transducer with splined shaft is indicated by the suffix /121.

OPTIONS

Flanges

Flanges are optional for torque transducers with splined shaft ends. Flange drawing is available on request.

Description	Model	P/N
Flange for Model 314/X21	FTM 214	415-214-960-011
Flange for Model 315/X21	FTM 215	415-215-960-011
Flange for Model 316/X21	FTM 216	415-216-960-011
Flange for Model 317/X21	FTM 217	415-217-960-011

SYSTEM OPTIONS AND ACCESSORIES

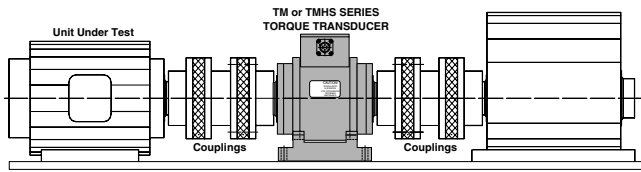

Supported Installation
Mandatory for high speed applications.

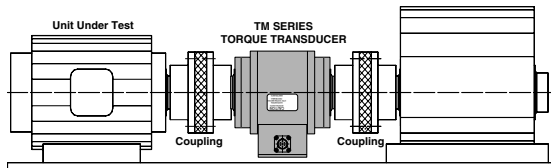

Suspended Installation
For low speed applications only, uses single-element couplings to create a shorter drive train.

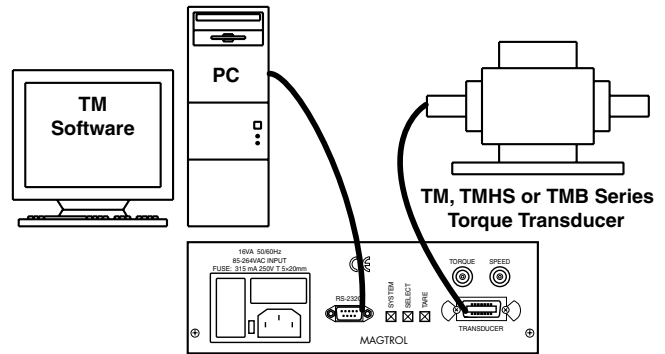

Model 3410 Torque Display

PC-Based System Configuration
Torque Transducer with Model 3410 Display and Torque Software

Couplings

When Magtrol TMB, TM and TMHS Series Torque Transducers are to be mounted in a drive train, double-element miniature couplings are the ideal complement, although single-element couplings can be used for low speed applications. Several manufacturers provide adequate couplings for both supported and suspended drive train installations. The criteria for selecting appropriate couplings for torque measurement is as follows:

- High torsional spring rate: Ensures high torsional stiffness & angular precision (should be > 3 times the torque transducer stiffness)
- Clamping quality (should be self-centering & of adequate strength)
- Speed range
- Balancing quality (according to speed range)
- Alignment capability

The higher the speed of the application, the more care is required in selecting the coupling and assembling (alignment and balancing) the drive train configuration. Your Magtrol sales representative can assist you in choosing the right coupling for your transducer.

ORDERING INFORMATION

Magtrol Torque Transducer model numbers must be preceded by the series type and followed by the appropriate suffix.

TORQUE TRANSDUCERS		
• Model TM 314-317	TM 3□□/0□1	1
Splined Shaft (314-317)		2
Keyway Shaft (314-315)		3
• Model TMHS 314-317	TMHS 3□□/1□1	1
Splined Shaft (314-317)		2
Keyway Shaft (314-315)		3

Torque Transducer Displays

Magtrol offers two different Torque Displays (Models 3410 and 6400) which supply power to any TM/TMHS/TMB Transducer and display torque, speed and mechanical power. Features include:

- Adjustable English, metric and SI torque units
- Large, easy-to-read vacuum fluorescent display
- Built-in self-diagnostic tests
- Overload indication
- Tare function
- RS-232 interface
- Torque and speed outputs
- Closed-box calibration
- Includes Magtrol TM Software

The Model 6400 Display has the following additional features:

- Pass/fail torque-speed-power testing capabilities
- RS-232 and IEEE-488 interface
- Auxiliary analog input

TM Software

Magtrol's TM Software is an easy-to-use Windows® executable program, used to automatically collect torque, speed and mechanical power data. The data can be printed, displayed graphically or quickly saved as a Microsoft® Excel spreadsheet. Standard features of Magtrol's TM Software include: peak torque capture, multi-axes graphing, measured parameter vs. time, adjustable sampling rates and polynomial curve fitting.

Accessories	Model #
Torque Transducer Connector Cable (5/10/20 m)	ER 113

Due to the continual development of our products, we reserve the right to modify specifications without forewarning.



MAGTROL INC
70 Gardenville Parkway
Buffalo, New York 14224 USA
Phone: +1 716 668 5555
Fax: +1 716 668 8705
E-mail: magtrol@magtrol.com

MAGTROL SA
Route de Moncor 4B
1701 Fribourg, Switzerland
Phone: +41 (0)26 407 3000
Fax: +41 (0)26 407 3001
E-mail: magtrol@magtrol.ch

Subsidiaries in:

- Germany
- France
- Great Britain

Worldwide Network
of Sales Agents

