

---

## **TF Series**

# **Torque Flange Sensor**

---

### **FEATURES**

- Complete Torque Measuring System consisting of:
  - Measuring Flange with Signal Amplifier
  - Antenna (Pickup)
  - Receiver
- Contactless Signal Transmission: via telemetry
- Torque Range: 50 N·m to 50,000 N·m
- High Accuracy: 0.1% to 0.25%
- Overload Capacity: 200%
- Overload Limit: 400%
- Compact, Easy-to-Mount Design
- High Torsional Stiffness
- Bearingless: maintenance and wear-free
- Excellent Noise Immunity and Shock Resistance
- Protection Class: IP 42 (IP 54 optional)
- 24 VDC Standard Power Supply
- Integrated Speed Pickup (option): for rotational speed measurement
- High Temperature Capability: up to 125 °C (optional)

### **DESCRIPTION**

With its compact, bearingless, maintenance-free design, the new TF Torque Flange Sensor from Magtrol brings many appealing advantages to torque measurement applications. The TF's high torsional rigidity supports direct mounting on the machine shaft or flange, avoiding the use of couplings on one side. This allows easy integration into a test system, shortens the overall length of the test bench and reduces costs.

Based on strain-gauge technology, the TF Sensor's precise telemetry system enables highly accurate signal transmission. A signal amplifier mounted in the measuring flange amplifies the measuring signal, modulates it to high frequency and transmits it inductively (via the stationary antenna) to the receiver. In the receiver, the digitized torque signal is transformed into an analog output signal of  $\pm 10$  VDC or 4–20 mA (option). Rotational speed can be measured and converted to a TTL output signal with the optional speed pickup.



*Model TF Torque  
Flange Sensor with  
Measuring Flange,  
Stationary Antenna  
and Receiver*

The contactless design of the Torque Flange Sensor permits a gap of up to 5 mm (typically 1 to 3 mm) between the rotor antenna and stator antenna, which makes the TF insensitive to any axial or radial misalignment. Another advantage of this torque measurement system is its insusceptibility to signal interference—due to the fact that, unlike other designs, the antenna does not need to be looped around the sensor. Additionally, a protective cover can be mounted close to the sensor with no effect on the signal.

### **APPLICATIONS**

TF Torque Flange Sensors measure both static and dynamic torque on rotating and stationary shafts. They are used in general combustion engine, electric motor and gearbox test benches; and can also be mounted inline for active torque monitoring of transmissions, powertrains, wind generators, gas turbines, boat engines, etc.

**BLOCK DIAGRAM**

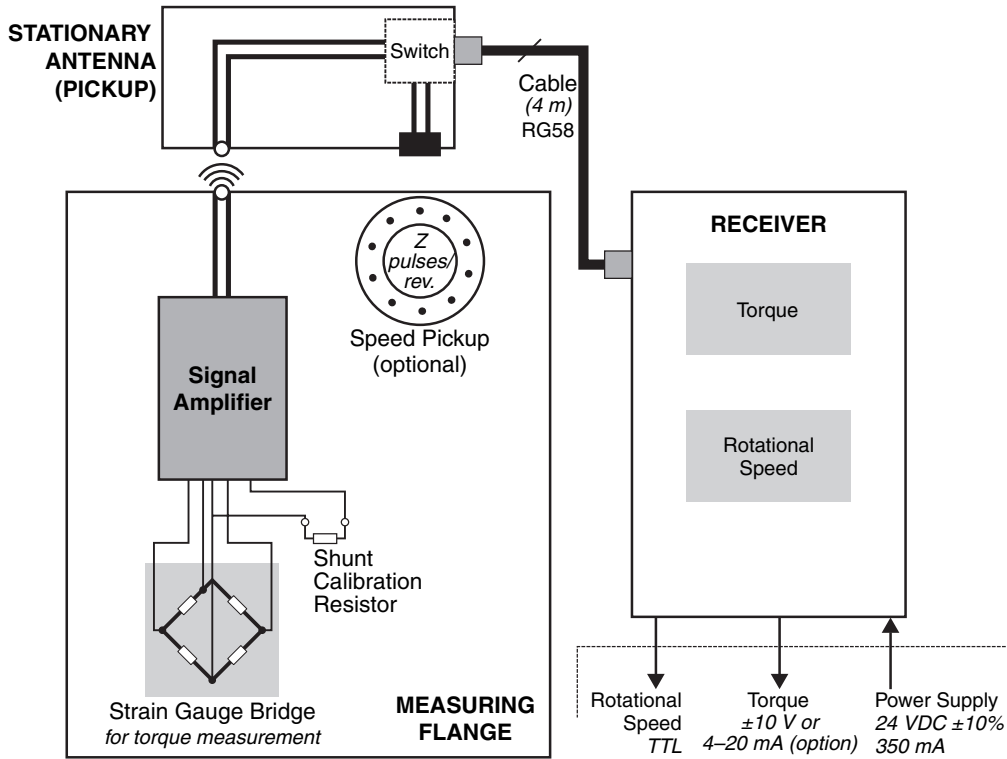

**SYSTEM CONFIGURATION**

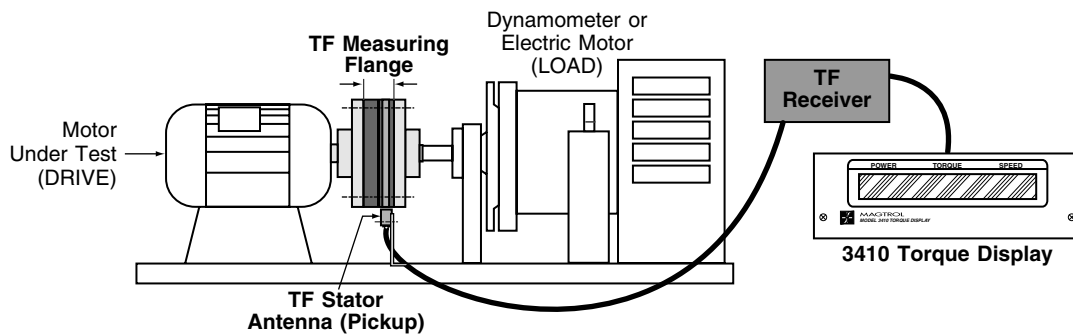

## RATINGS

TF Model Number:	210	211	212	213	214	215	216	217	218	219
<b>TORQUE MEASUREMENT</b>										
Nominal Rated Torque (RT)	50 N·m	100 N·m	200 N·m	500 N·m	1 kN·m	2 kN·m	5 kN·m	10 kN·m	20 kN·m	50 kN·m
Combined Error of Linearity and Hysteresis	0.1%							0.15%	0.25%	
Maximum Dynamic Torque Peak Value (Overload Capacity)	200% of RT									
Maximum Dynamic Torque Without Damage (Overload Limit)	400% of RT									
Deformation Angle by Nominal Torque	< 0.005°									
<b>SPEED MEASUREMENT</b>										
Rated Speed	1 to 14,000 rpm			1 to 8000 rpm			1 to 4000 rpm		1 to 1500 rpm	
Number of Teeth *	70 Z	70 Z	70 Z	91 Z	91 Z	113 Z	133 Z	133 Z	283 Z	283 Z
<b>ENVIRONMENT</b>										
Rated Temperature Range	+10 °C to +85 °C									
Storage Temperature Range	-25 °C to +85 °C									
Extended Temperature Range (option)	-30 °C to +125 °C									
Temperature Influence on Zero	0.005% / °C									
Protection Class	IP 52 (optional IP 65)									
<b>INPUT AND OUTPUT SIGNALS</b>										
Power Supply	24 VDC ±10%, max 350 mA									
Torque Output Signal (rated / max)	±5 VDC / ±10 VDC (option: 4–20 mA)									
Speed Output (option)	TTL / Z pulses per revolution									
Passband Frequency	0 to 1 kHz (-3 dB)									

\* Inductive speed detection available on request.

## MOMENT OF INERTIA

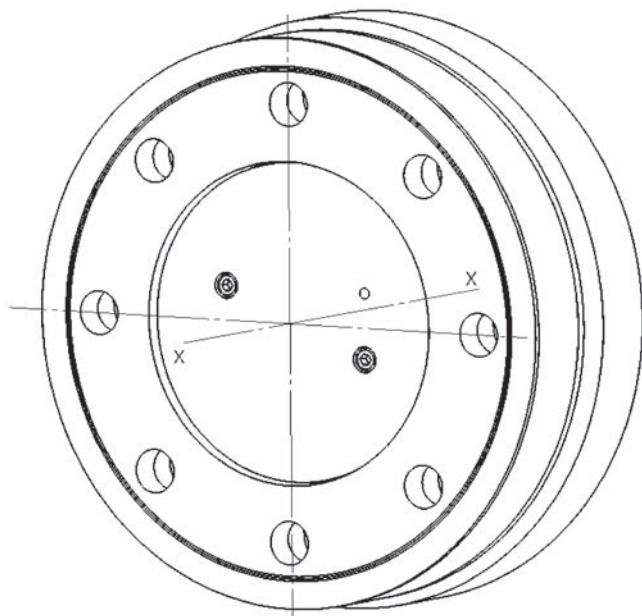

Model	Rated Torque	Moment of Inertia (of X-axis)	
		kg·m <sup>2</sup>	lb·ft·s <sup>2</sup>
TF 210	50	1.846 × 10 <sup>-3</sup>	1.362 × 10 <sup>-3</sup>
TF 211	100	1.923 × 10 <sup>-3</sup>	1.419 × 10 <sup>-3</sup>
TF 212	200	1.926 × 10 <sup>-3</sup>	1.419 × 10 <sup>-3</sup>
TF 213	500	4.918 × 10 <sup>-3</sup>	3.630 × 10 <sup>-3</sup>
TF 214	1,000	4.918 × 10 <sup>-3</sup>	3.630 × 10 <sup>-3</sup>
TF 215	2,000	1.026 × 10 <sup>-2</sup>	7.569 × 10 <sup>-3</sup>
TF 216	5,000	2.503 × 10 <sup>-2</sup>	1.847 × 10 <sup>-2</sup>
TF 217	10,000	2.503 × 10 <sup>-2</sup>	1.847 × 10 <sup>-2</sup>
TF 218	20,000	4.672 × 10 <sup>-1</sup>	3.448 × 10 <sup>-1</sup>
TF 219	50,000	4.672 × 10 <sup>-1</sup>	3.448 × 10 <sup>-1</sup>



**TF 215 (2 kN·m)**

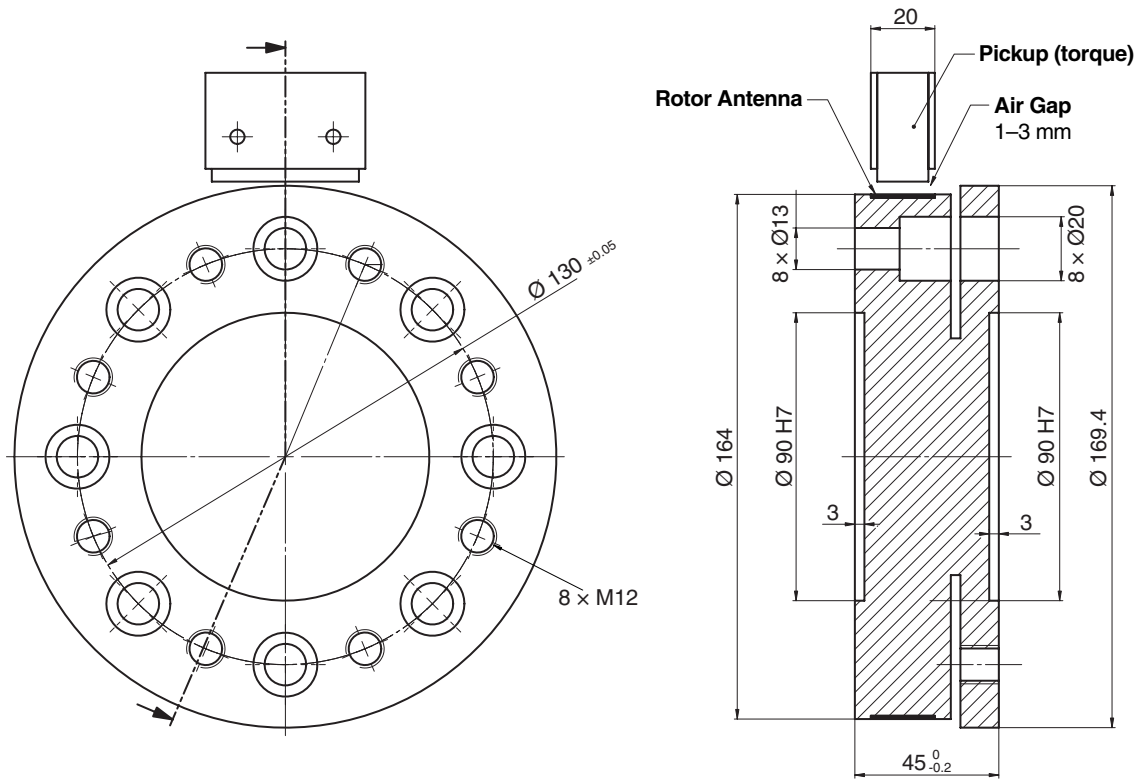

**TF 216 (5 kN·m)**

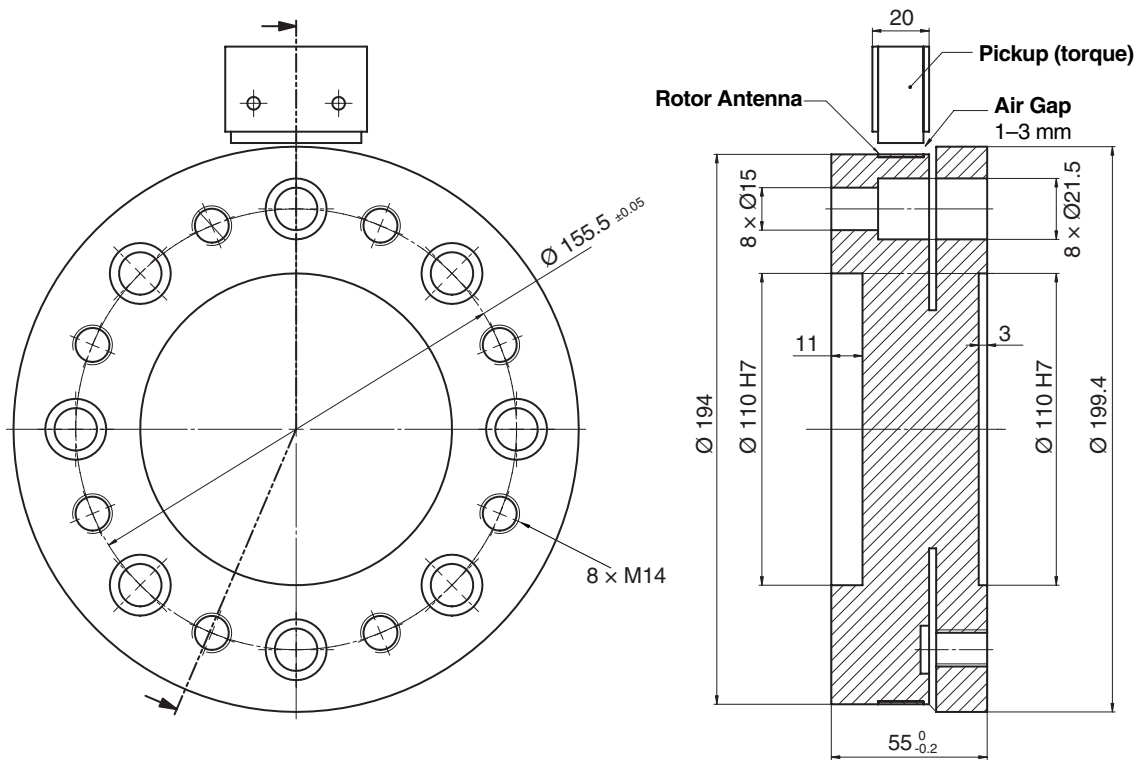

**TF 217 (10 kN-m)**

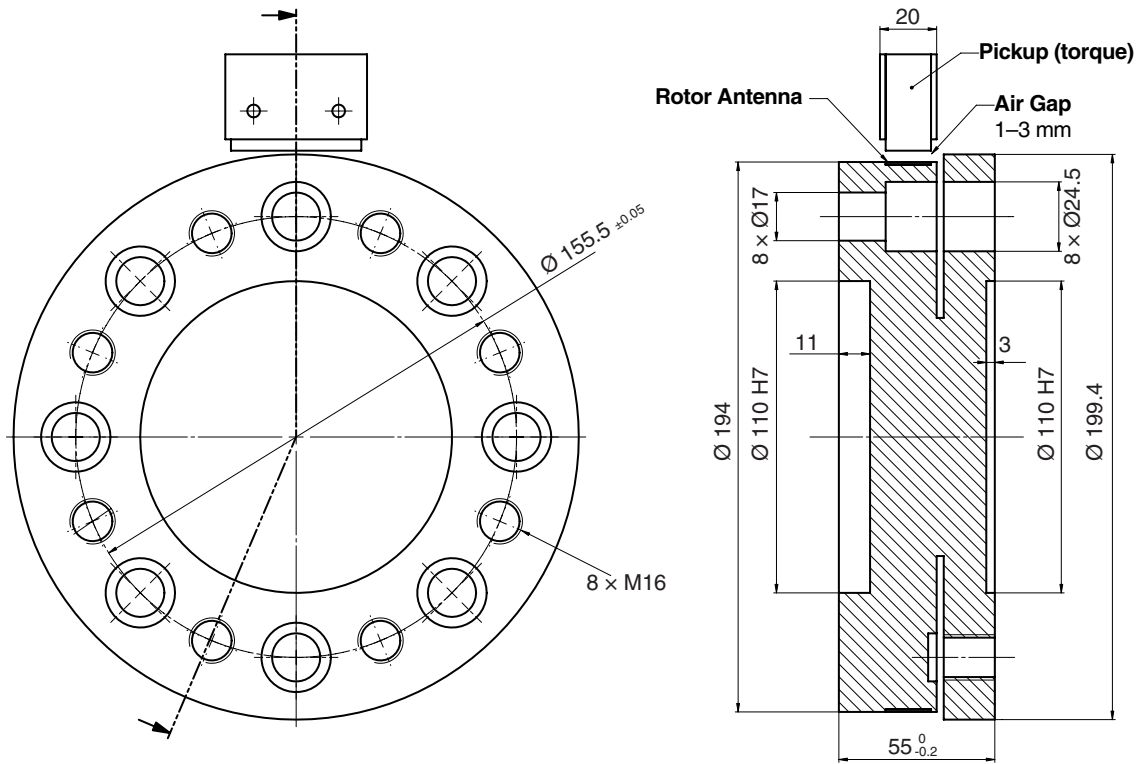

**TF 218 (20 kN-m) and TF 219 (50 kN-m)**

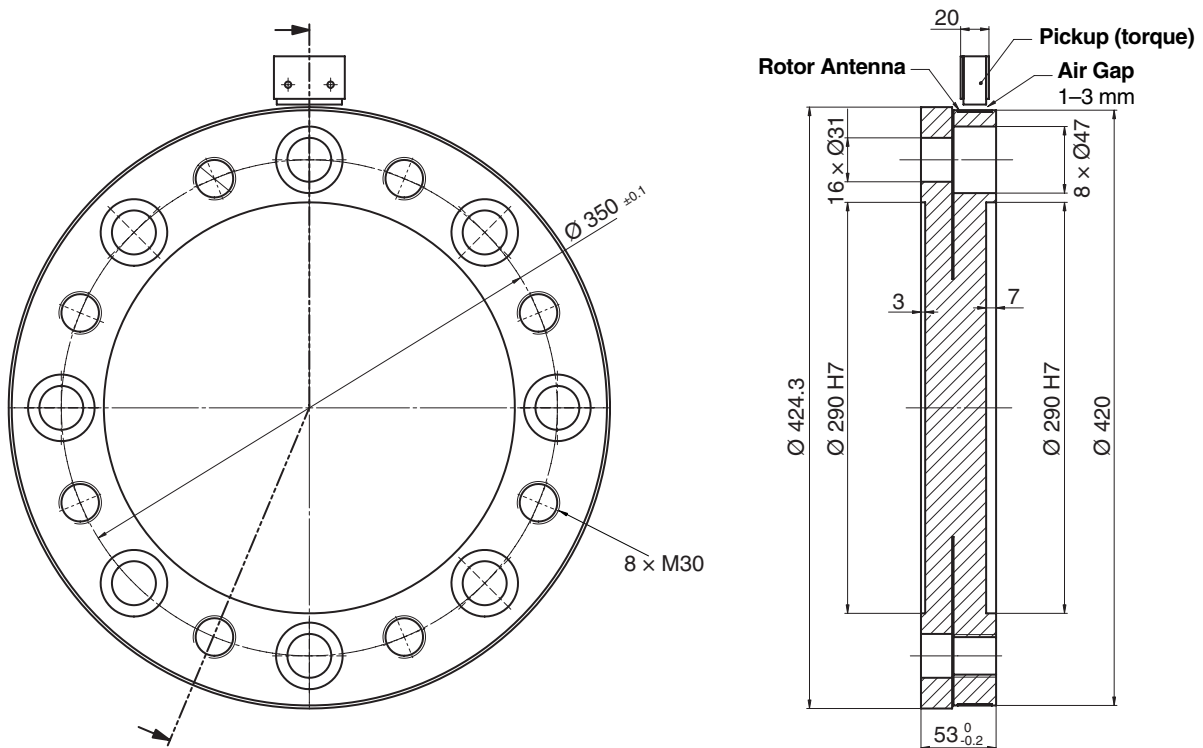

## OPTIONS AND ORDERING INFORMATION

<b>MODEL NUMBER:</b>	TF 2 <input type="text"/> <input type="text"/> / 0 <input type="text"/> 1
MODEL TF 2 <input type="text"/> <input type="text"/> - 2 <input type="text"/> <input type="text"/>	
<b>SPEED PICKUP / OUTPUT</b>	
• without (standard)	1
• with (option)	2

## SYSTEM OPTIONS

### Model 3410 Torque Transducer Display

Magtrol offers the new Model 3410 Display which supplies power to any TF Sensor and displays torque, speed and mechanical power. Features include:

- Adjustable English, metric and SI torque units
- Large, easy-to-read vacuum fluorescent display
- Built-in self-diagnostic tests
- Overload indication
- Tare function
- RS-232 interface
- Torque and speed outputs
- Closed-box calibration
- Includes Magtrol TM Software

### TM Software

Magtrol's TM Software is an easy-to-use Windows® executable program, used to automatically collect torque, speed and mechanical power data. The data can be printed, displayed graphically or quickly saved as a Microsoft® Excel spreadsheet. Standard features of Magtrol's TM Software include: peak torque capture, direction of rotation, multi-axes graphing, measured parameter vs. time, adjustable sampling rates and polynomial curve fitting.

Parts	Model #
Torque Transducer Connector Cable (5/10/20 m)	ER 116

## PC-Based System Configuration

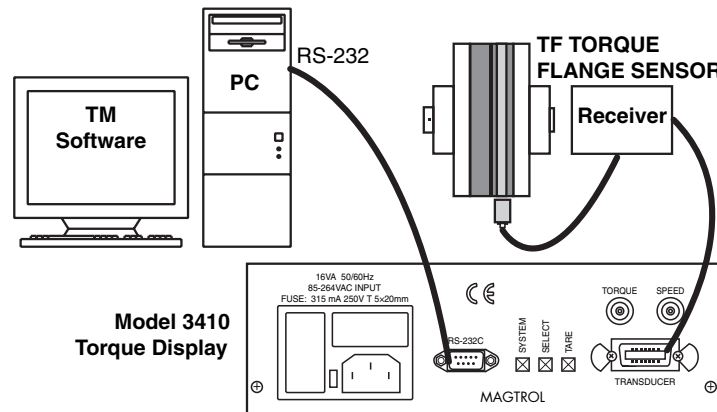

*Due to the continual development of our products, we reserve the right to modify specifications without forewarning.*



[www.magtrol.com](http://www.magtrol.com)

**MAGTROL INC**  
 70 Gardenville Parkway  
 Buffalo, New York 14224 USA  
 Phone: +1 716 668 5555  
 Fax: +1 716 668 8705  
 E-mail: magtrol@magtrol.com

**MAGTROL SA**  
 Route de Moncor 4B  
 1701 Fribourg, Switzerland  
 Phone: +41 (0)26 407 3000  
 Fax: +41 (0)26 407 3001  
 E-mail: magtrol@magtrol.ch

**Subsidiaries in:**

- Germany
- France
- Great Britain
- China

Worldwide Network  
 of Sales Agents

