

LMU 112 and LMU 117 Load Monitoring Units

LMU 112 FEATURES

- For Use with Full-bridge Strain Gauge Transducers (Sensitivity 0.5 to 2 mV/V)
- Voltage Input for Different Charge Summation
- 2 Level Detectors with Relay Output Contacts
- 0 to 20 mA DC Current Output
- ± 10 V Voltage Output
- Provides Continuous Detection of Signal Line Failure and Short Circuits
- Compatible to CE Standards
- IP 65 Aluminium Housing

LMU 117 FEATURES

- Composed of Two LMU 112 Units
- Same Features as the LMU 112

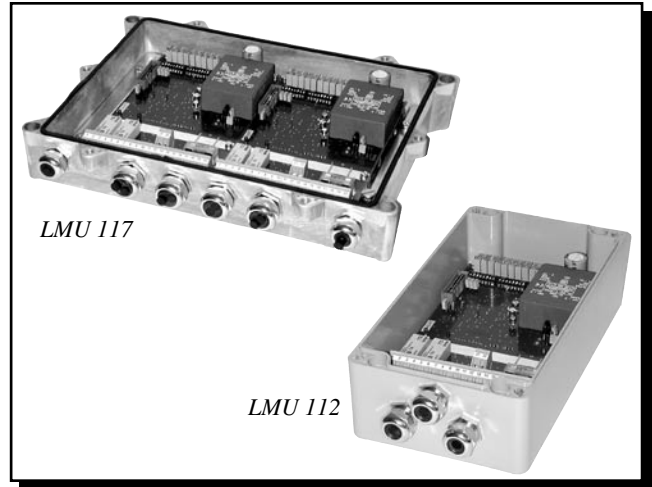

DESCRIPTION

The Magtrol LMU Load Monitoring Unit is specially designed for strain gauge transducer applications. It is flexible and fully configurable due to DIP-switches and jumpers which allow the unit to be easily installed—no solder connections are required.

The LMU 112 contains 1 full-bridge strain gauge transducer input, 1 voltage input, 2 level detectors (output contacts), 1 current output, 1 voltage output and 2 "OK" self-test signals for monitoring the correct operation while running several LMU units simultaneously. The level detectors and the outputs can be dedicated either to the full-bridge input, to the voltage input or to the sum of both

The LMU 112/LMU 117 is used with Magtrol Load Measuring Pins which measure load and force and provide overload protection. Magtrol also offers a wide range of Load-Force-Weight Transducers in various executions and accuracy classes and our Digital Process Monitors/Signal Conditioners measure and display load, force and weight from signals generated by strain gauge transducers.

(see "Application Selection" at bottom of page 2). A built-in self-test system detects any short circuits or signal line failures, **thus allowing the system to be used in applications where safety is important.** If a problem is detected, both relays are deactivated and the output voltage (respective current) changes to >10 VDC (>20 mA).

The LMU is fully compatible with European Community (CE) standards. Its IP 65 aluminium housing allows the system to be used in harsh environments. Using SMD (surface mounted device) technology, the LMU allows the maximum performance/price ratio for strain gauge transducer monitoring.

SYSTEM CONFIGURATION

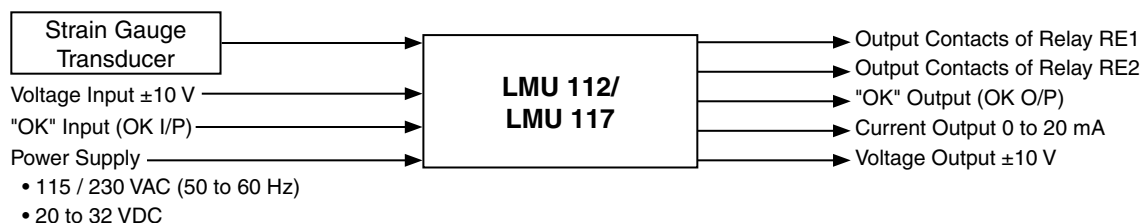

INPUT CHARACTERISTICS		
Power Supply		
Voltage	115 VAC/230 VAC (50–60 Hz) or 20 to 32 VDC, jumper selectable	
Maximum Current	Current	
	Fuse Rating	
	70 mA for 230 VAC	80 mA
	150 mA for 115 VAC	160 mA
250 mA for 20 VDC	400 mA	
Bridge Signal		
Supply Voltage	10 VDC	
Max. Possible Current	150 mA DC	
Sensitivity	0.5 to 2 mV/V	
Max. Dynamic Component of Bridge Signal	±30 mV DC	
Max. Common Mode Voltage on Input	±10 V	
Voltage Input for Summation of Another Load		
Input Impedance	200 kΩ	
Max. Input Signal (dynamic)	±10 V	
Input for Self-Test Feature (OK I/P)		
Type	Active if short circuited	
OUTPUT CHARACTERISTICS		
Relay Outputs		
Number	2 (RE 1; RE 2)	
Normal State	Normally energized	
Max. Current per Contact	5 A continuous / break 20 A on startup	
Max. Voltage per Contact	AC: 250 V _{rms} DC: 350 VDC	
Max. Break Power	100 W or 1000 VA	
Insulation Voltage	Contact-Contact: 750 V _{rms} Contact-Coil: 1.5 kV _{rms}	
Lifetime	> 2 × 10 ⁸ switchings	
Contact Resistance	< 20 mΩ	
Current Output		
Output Type	Current generator	
Nominal Current Range	0 to 20 mA DC	
Max. Current Range	0 to 25 mA DC	
Max. Load	< 500 Ω for I _{max} = 20 mA	
Output Impedance	> 50 kΩ	
Voltage Output		
Max. Value	±10 V ≡ FSD	
Max. Load	≥10 kΩ(ε≤1%)[≥2 kΩ(ε≤5%)]*	
Output Impedance	100 Ω (in series)	
Output for Self-Test Feature (OK O/P)		
Type	Open collector (short circuit-proof)	

* Refer to NOTE on following page.

TRANSFER CHARACTERISTICS			
Voltage Transfer Ranges ($\Delta U_{I/P} / \Delta U_{O/P}$)			
Range	1	2	3
Bridge Sensitivity [mV/V]	0.42 to 0.78 (0.6)	0.7 to 1.3 (1)	1.2 to 2.2 (1.7)
Voltage Transfer (gain)	2380 to 1280 (1670)	1428 to 769 (1000)	833 to 455 (588)
Adjustment Range	±30%	±30%	±30%
Range Selection	Using DIP-switches		
Zero Adjustment for Measuring Chain	Coarse adjustment using multi-turn potentiometer: equivalent to ± 10 V/output for Range 3 Fine adjustment using multi-turn potentiometer: 5% of the coarse adjustment		
Temperature Drift of Transfer Function	≤ 200 ppm/°C		
Temperature Drift of 0	≤ 200 ppm of FSD/°C for range 0.5 mV/V ≡ 1 μV/°C		
Current Transfer Range			
Sensitivity Range with Multi-turn Potentiometer	± 20% of FSD on U _{O/P}		
Nominal Current Range	0 to 20 mA DC		
Max. Current Range	0 to 25 mA DC		
Zero Adjustment Range	± 5 mA DC for I _{O/P} ≥ 5 mA DC		
Selectable Low-Pass Filter			
Filter Type	Butterworth		
Filter Order	2nd		
-3dB Cut-off Frequency	Selectable using DIP-switches to 0.3 Hz; 1 Hz; 3 Hz; 10 Hz		
Transfer Function Between Summing Input/Voltage Output	1		
Level Detectors			
Number of Detectors	2 (REL1; REL2)		
Level Adjustment Range	-10 to +10 VDC using multi-turn potentiometer (measured on voltage output)		
Hysteresis	0 or ≈ 5% (selectable using DIP- switches)		
Detection Indication	< or > (selectable using DIP-switches)		
Switching Delay			
Number of Circuits	2		
Delay Adjustment Range	0 to 5 seconds using multi-turn potentiometer		
Application Selection			
Selection	Det. REL1	Det. REL2	U_{O/P}, I_{O/P}
1	A	A	A
2	A + B	A	A + B
3	A	A + B	A
4	A + B	A + B	A + B
5	B	B	B
6	A + B	B	A + B

A = Bridge signal; B = Voltage input

MECHANICAL CHARACTERISTICS	
Housing	
Material	Aluminum
Weight	≈2 kg; ≈4.41 lb
Stuffing Glands	
Number and Type	3 × PG 11
Material	Nickel-plated brass
Terminal Strip	
Type	MK8 (screw at 45° and connection at 45°)
Max. Area of Connecting Wire	AWG 20 to 16 Cross-section: 0.5 to 1.5 mm ² (≈0.00077 to 0.0023 in ²)

ENVIRONMENTAL CHARACTERISTICS	
Operating Temperature	-40°C to +80°C
Storage Temperature	-45°C to +85°C
Protection Class	IP 65
Vibration and Shock	According to IEC 68.2
EMC	According to EN-58081-2 (Generic Emission Standard) and EN-58082-2 (Generic Immunity Standard)

* **NOTE:** In order to guarantee a precise calibration, the customer is asked to indicate the impedances of the connected unit together with the order. If this value is unknown, an impedance of 1 MΩ will be used for calibration. The resulting deviation will be in the order of ≤5% with an impedance of ≥2 kΩ or ≤1% with ≥10 kΩ.

LMU 112 DIMENSIONS

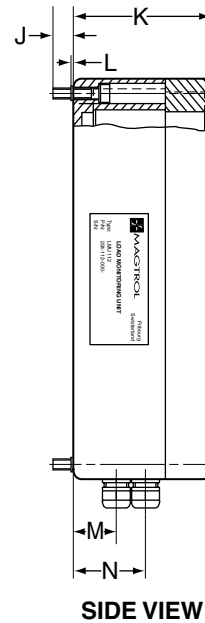
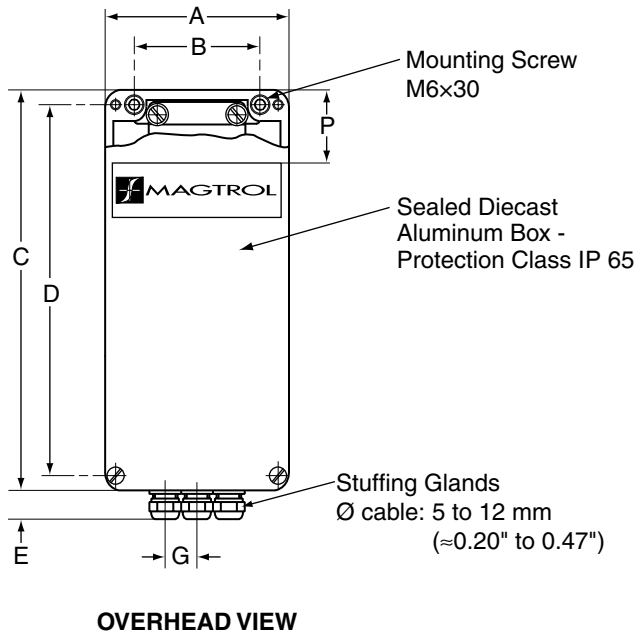

NOTE: Original dimensions are in Metric units. Dimensions converted to English units have been rounded up to 2 decimal places.

	mm	in
A	120	4.72
B	82	3.23
C	220	8.66
D	204	8.03
E	≈16	0.63
G	20.75	0.82
J	13.4	0.53
K	90	3.54
L	≈1.5	0.06
M	28	1.10
N	47	1.85
P	40	1.57

LMU 112 ORDERING INFORMATION

PART NUMBER	DESCRIPTION
224-112-000-021	LMU 112 Load Monitoring Unit – standard model with no setup and no calibration
224-112-000-021C	LMU 112 Load Monitoring Unit – setup and calibration according to the configuration and calibration report PY 7606 (to be filled according to the application)

LMU 117 DESCRIPTION

The LMU 117 Load Monitoring Unit is a dual-channel electronic device composed of two LMU 112s assembled in an aluminium housing (the connection between power supplies is factory-made).

When using several load monitoring units, the "OK" feature allows the operation of all units to be monitored using a single "OK" input or output

THE INPUT, OUTPUT, TRANSFER, ENVIRONMENTAL AND MECHANICAL CHARACTERISTICS OF THE LMU 117 ARE IDENTICAL TO THOSE OF THE LMU 112.

LMU 117 DIMENSIONS

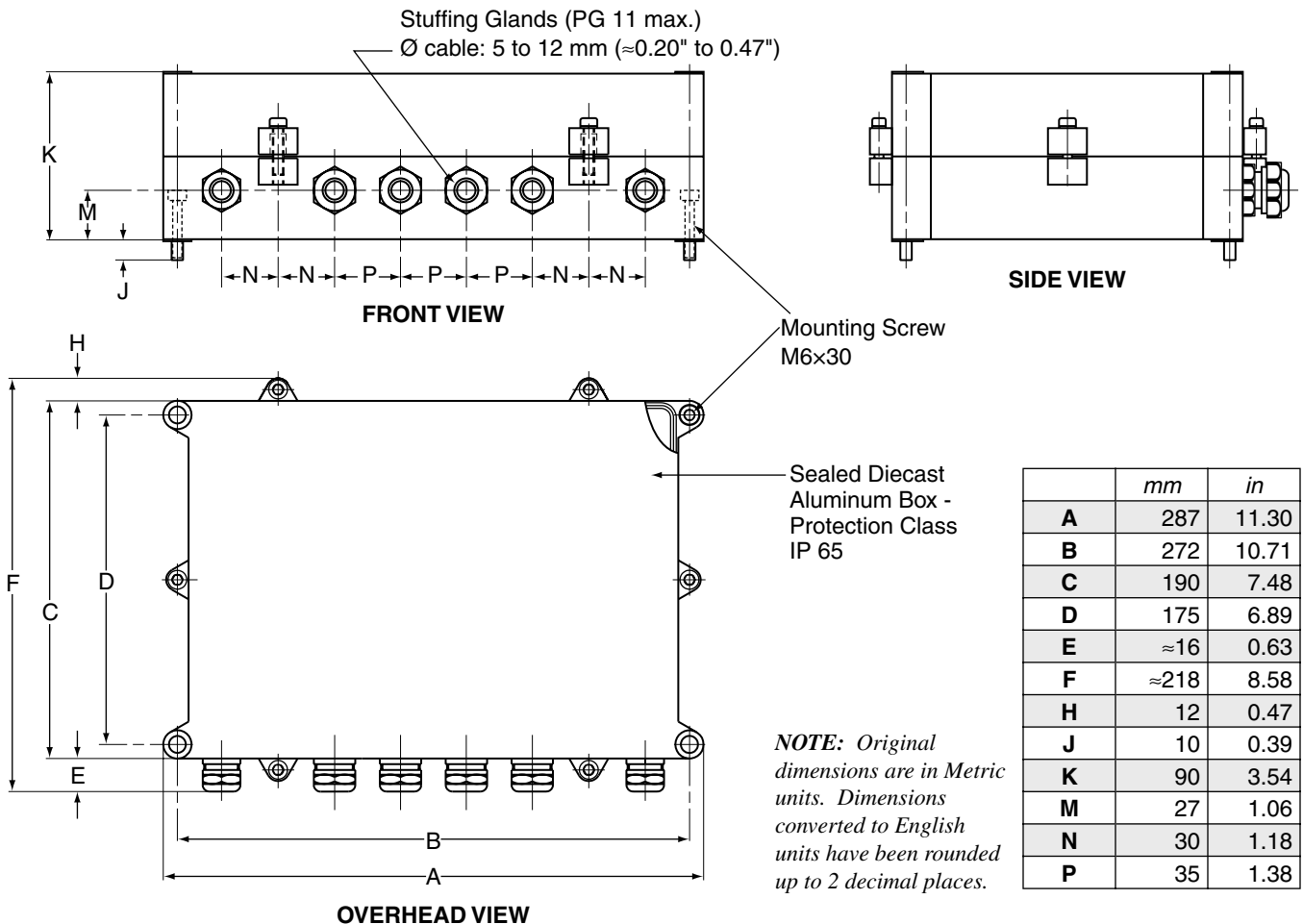

LMU112DS-US www 03/03

LMU 117 ORDERING INFORMATION

PART NUMBER	DESCRIPTION
224-117-000-011	LMU 117 Load Monitoring Unit – standard module with no setup and no calibration
224-117-000-011C	LMU 117 Load Monitoring Unit – setup and calibration according to the configuration and calibration report PY 7606 (to be filed according to the application)

Due to the continual development of our products, we reserve the right to modify specifications without forewarning.

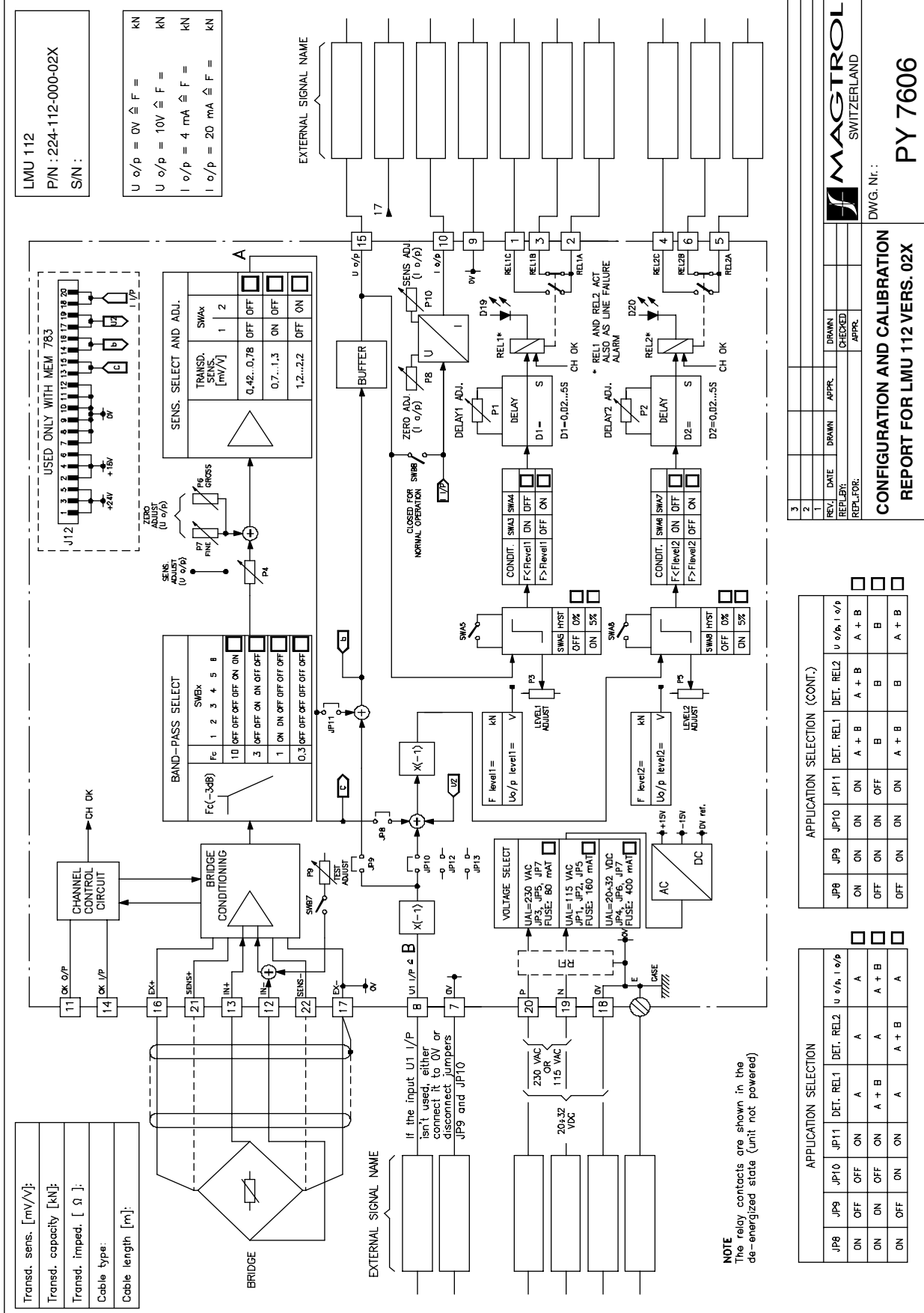

REV.	DATE	DRAWN	APPR.	CHECKED	APPR.
1					
2					
3					

MAGTROL
SWITZERLAND

DWG. Nr.: **PY 7606**

CONFIGURATION AND CALIBRATION REPORT FOR LMU 112 VERS. 02X

APPLICATION SELECTION (CONT.)

JP8	JP9	JP10	JP11	DET. REL1	DET. REL2	U o/p, I o/p
ON	ON	ON	ON	A + B	A + B	A + B
OFF	ON	ON	ON	B	B	B
OFF	ON	ON	ON	A + B	B	A + B

APPLICATION SELECTION

JP8	JP9	JP10	JP11	DET. REL1	DET. REL2	U o/p, I o/p
ON	OFF	OFF	ON	A	A	A
ON	ON	OFF	ON	A + B	A	A + B
ON	OFF	ON	ON	A	A + B	A



www.magtrol.com

MAGTROL INC

70 Gardenville Parkway
Buffalo, New York 14224 USA
Phone: +1 716 668 5555
Fax: +1 716 668 8705
E-mail: magtrol@magtrol.com

MAGTROL SA

Route de Moncor 4B
1701 Fribourg, Switzerland
Phone: +41 (0)26 407 3000
Fax: +41 (0)26 407 3001
E-mail: magtrol@magtrol.ch

Subsidiaries in:

- Germany
- France
- Great Britain

Worldwide Network
of Sales Agents

Magtrol SA ISO 9001:2000 certified

