

DES 310 and DES 311 Power Supplies

FEATURES

- For use with Magtrol WB Eddy-Current and PB Powder Brake Dynamometers
- Controlled current supply, with overvoltage factor > 5
- Analog input for current set-point
- Selection of nominal current
- Control by digital inputs/outputs
- General alarm provided by relay
- 2 alarm outputs (temperature and electrical circuit)
- Available in either 115 or 230 VAC

DESCRIPTION

DES 310 and DES 311 Power Supplies are suited to the entire range of Magtrol's Eddy-current and powder brake dynamometers. To avoid any disruption of the surrounding electronic modules, the DES 310 / DES 311 supplies are fitted in an industrial housing made of extruded cast aluminium. This housing must be installed directly on the test bench, as close to the dynamometer as possible.

The DES 310 / DES 311 supplies can be controlled by analog and digital set-points coming from an electronic peripheral, ideally from the DSP6001 Dynamometer Controller.

Control

The Power supplies can be switched on by remote control. A stand-by command allows the dynamometer power to be activated. The excitation current is controlled by a set-point in the range of 0 to 10VDC. The nominal value of the excitation current is adjustable by internal resistors or remotely.



There are two digital outputs (alarms): one is an electrical fault indicator and the other detects overheating in the DES unit or the cooling water. If one of the alarms is activated, a general alarm is signalled by means of relay contacts.

For applications with tandem dynamometers, the DES 310/ DES 311 units also control the power supply of the electromagnetic clutch.

Supply Voltage

The supply voltage of the DES 310/DES 311 can be selected to allow operation at either 230 VAC or 115 VAC (50/60 Hz).

The DES 310 power supply includes a galvanic separation between the supply circuit and the dynamometer power. Because of the power required, the supply to the DES 311 unit is made directly without galvanic separation.

SYSTEM CONFIGURATION

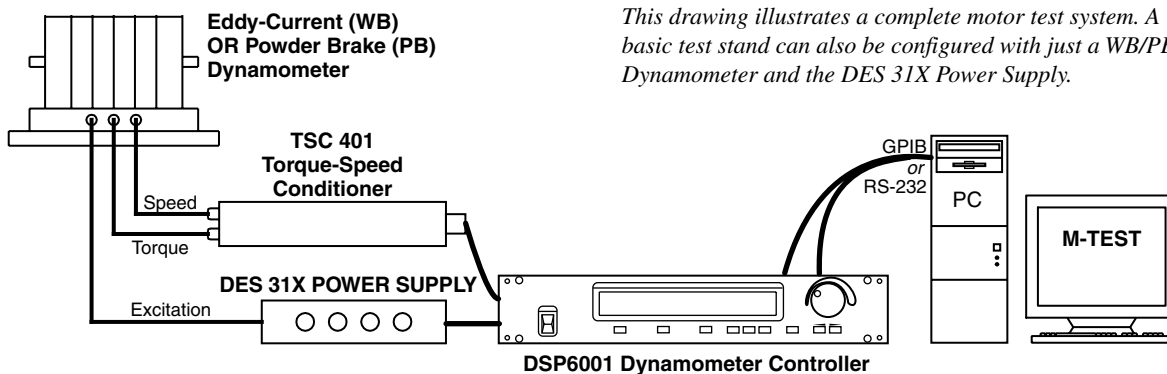

This drawing illustrates a complete motor test system. A basic test stand can also be configured with just a WB/PB Dynamometer and the DES 31X Power Supply.

RATINGS

	DES 310	DES 311
NETWORK SUPPLY		
Voltage	115 VAC / 230 VAC $\pm 15\%$	
Frequency	50 Hz / 60 Hz	
Fuse	T1A or T2A depending on the brake(s)/ 115–230 VAC	T2A to T12A depending on the brake(s)/ 230 VAC 115 VAC
Maximum current	1 A + clutch	3 A + clutch / 230 VAC 6 A + clutch / 115 VAC
ELECTROMAGNETIC CLUTCH SUPPLY		
Voltage	115 VAC / 230 VAC	
Current	1 A	
SUPPLY FOR EXTERNAL USE		
Voltage	+24 VDC $\pm 10\%$	
Maximum Current	300 mA	
SELECTION OF NOMINAL CURRENT		
(Selected by resistors)	0.5 A; 1.0 A; 1.5 A; 2.0 A; 2.5 A; 3.0 A	2.5 A; 4.0 A; 5.0 A; 7.5 A; 10.0 A; 12.0 A
EXCITATION SET-POINT		
Voltage	0 to 10 VDC	
Impedance	$> 10\text{ k}\Omega$	
DIGITAL INPUTS		
Remote Control of the Network Input	Relay activated by +24 VDC / 30 mA	
Control of the Electromagnetic Clutch	Relay activated by +24 VDC / 15 mA	
Stand-by (enable)	Optocoupler activated by +24 VDC / 10 mA	
DIGITAL OUTPUTS		
Alarms	2 open collector outputs: temperature, electrical circuit $U_{\max} = 30\text{ V}$, $I_{\max} = 100\text{ mA}$	
GENERAL ALARM		
Relay Contact	10 A / 230 VAC	
ENVIRONMENTAL CHARACTERISTICS		
Operating Temperature	0°C to +50°C	
Storage Temperature	-20°C to +70°C	
Humidity	0 to 90% as per DIN 40040	
Protection Class	IP 66	
Assembly	 The housing must be electrically and thermally coupled to the metal frame of the test bench to allow heat dissipation.	
MECHANICAL CHARACTERISTICS		
Housing	Extruded cast aluminium	
Weight	2.5 kg; 5.51 lb	

DIMENSIONS

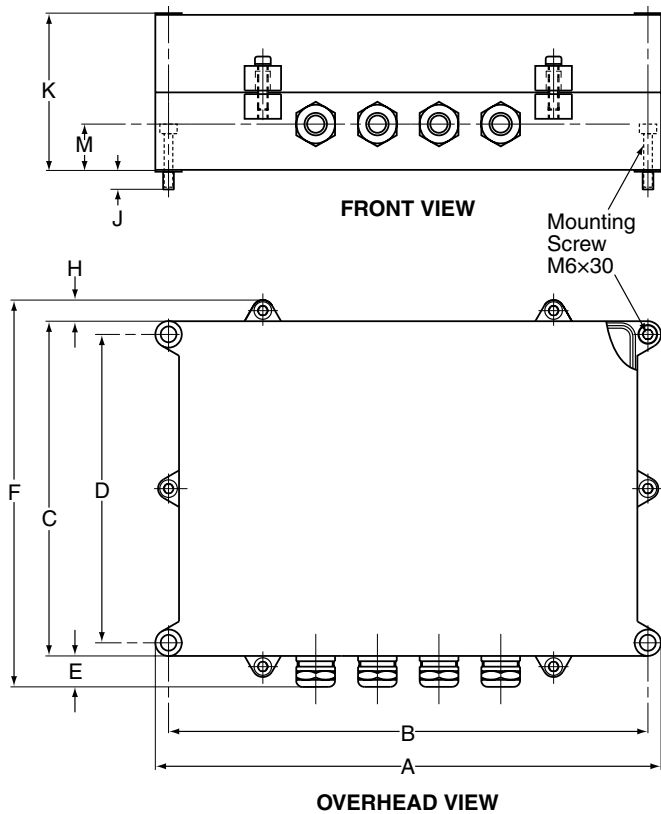

DES 311 Water Cooling System
(For all 15 series Dynamometers
except 1 WB 15 and 1 PB 15)

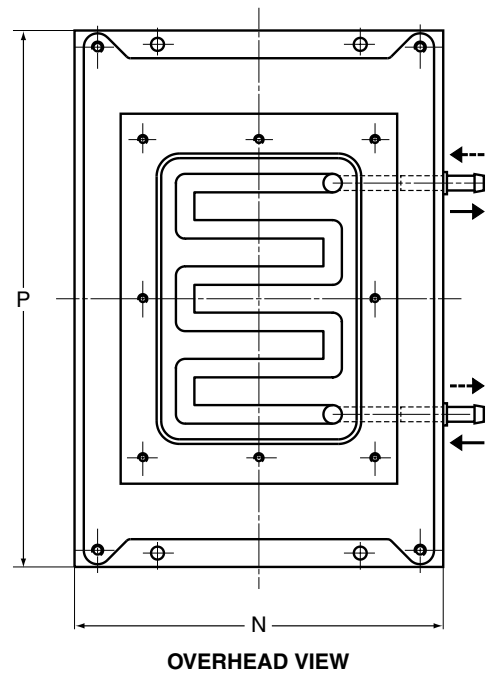
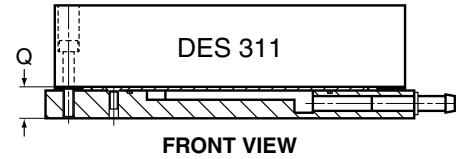

NOTE: Original dimensions are in Metric units.
Dimensions converted to English units have been rounded up
to 2 decimal places.

	A	B	C	D	E	F	H	J	K	M
mm	287	272	190	175	≈16	≈218	12	10	90	27
in	11.30	10.71	7.48	6.89	0.63	8.58	0.47	0.39	3.54	1.06

	N	P	Q
mm	200	290	15
in	7.87	11.42	0.59

The DES 310/DES 311 supplies are delivered with integrated cables (including connectors) with a length of 1.5 meters on the dynamometer connection side and 5 meters on the controller side. The DES 310/DES 311 units are to be mounted on a metallic surface in order to allow ample heat dissipation. For 3-4 WB 15 and 4 PB 15 dynamometers, the DES311/131 Power Supply with integrated Water Cooling System (see above drawing) should be used.

BLOCK DIAGRAM

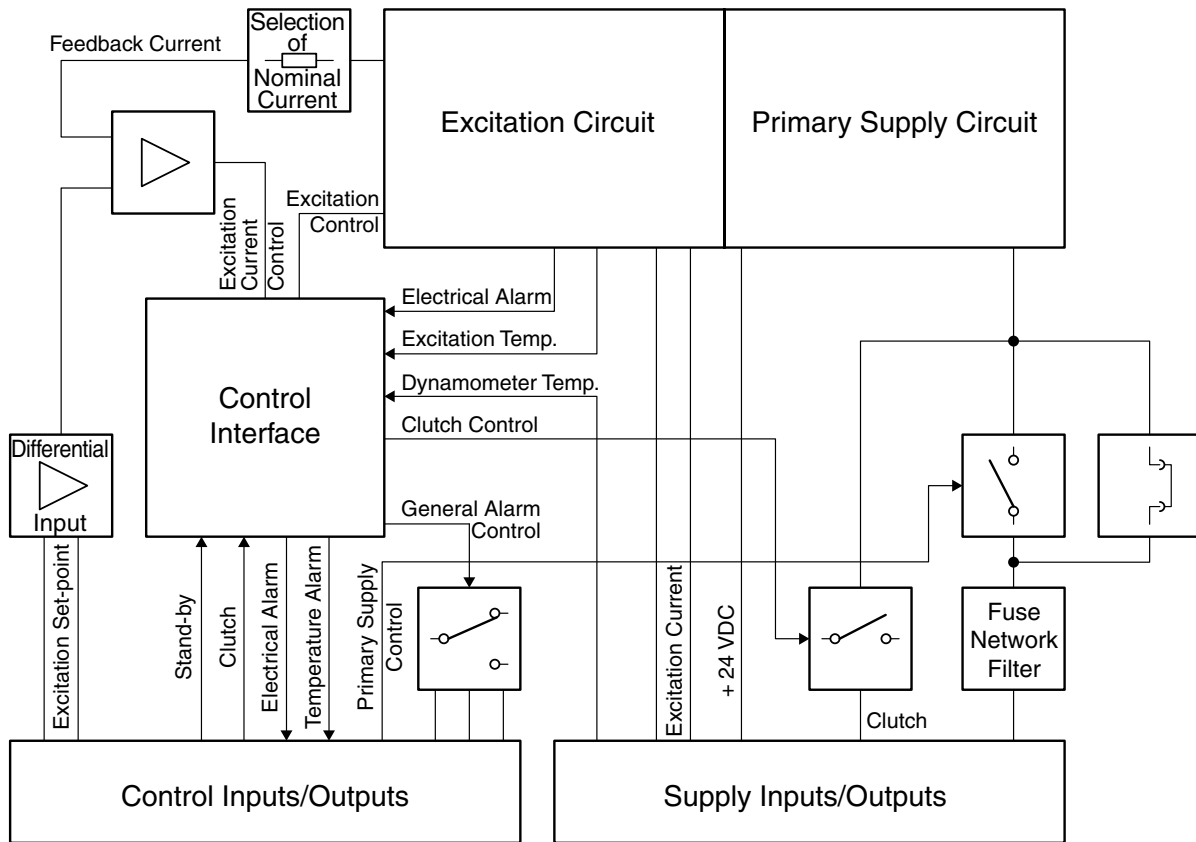

OPTIONS AND ORDERING INFORMATION

If the DES is ordered separately (from the dynamometer), it is absolutely necessary to specify which model of Eddy-current/ powder brake will be used with the power supply in order to limit the operating current and prevent possible damage to the dynamometer brake. Power voltage (115 VAC or 230 VAC) should also be defined when ordering.

DESCRIPTION	MODEL	PART NUMBER
Power Supply for WB/PB 2.7 and 43 Dynamometers	DES 310/111	234-310-000-111
Power Supply for WB/PB 65, 115, 1 PB 15 and 1 WB 15 Dynamometers	DES 311/121	234-311-000-121
Power Supply with Water Cooling Plate for 3-4 WB 15 and 4 PB 15 Dynamometers	DES 311/131	234-311-000-131

NOTE: All DES 31X Power Supplies include the corresponding dynamometer connection cables.

Due to the continual development of our products, we reserve the right to modify specifications without forewarning.



www.magtrol.com

MAGTROL INC
 70 Gardenville Parkway
 Buffalo, New York 14224 USA
 Phone: +1 716 668 5555
 Fax: +1 716 668 8705
 E-mail: magtrol@magtrol.com

MAGTROL SA
 Route de Moncor 4B
 1701 Fribourg, Switzerland
 Phone: +41 (0)26 407 3000
 Fax: +41 (0)26 407 3001
 E-mail: magtrol@magtrol.ch

Subsidiaries in:

- Germany
- France
- Great Britain

Worldwide Network
 of Sales Agents

