

CURRENT TRANSFORMER

Model CTW6-125

Wound primary CT

REGULATORY AGENCY APPROVALS



E145172



LRB9403

Manufactured to meet the requirements of ANSI/IEEE C57.13, Classified by UL in accordance with IEC 44-1

Approved for revenue metering by Industry Canada, AC-0662 Rev.01

APPLICATION:
Metering and relaying.

FREQUENCY:
50-400 Hz.

MAXIMUM SYSTEM VOLTAGE:
25.5kV, BIL 125kV full wave.

CONTINUOUS THERMAL CURRENT RATING FACTOR:
1.50 at 30°C. amb., 1.33 at 55°C. amb.

- Primary terminals are 1/2-13 bolts with one Belleville washer.
- Secondary terminals are 10-32 brass screws with one flatwasher and lockwasher.
- Vacuum cast in polyurethane resin.
- The transformers are tested for partial discharge to Canadian Standards CAN3-C13-M83. This test can also be carried out to IEC requirements if requested.
- Approximate weight: T100 - 95 lbs.
T200 - 115 lbs.

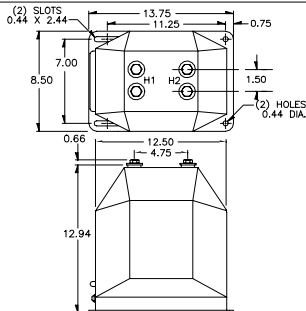
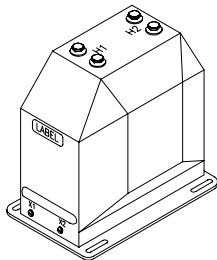

CAUTION: Use only the Belleville washers supplied. Tighten to between 25 to 30 foot-pounds. DO NOT OVERTIGHTEN.

CATALOG NUMBER***	CURRENT RATIO	RELAY CLASS	ANSI METERING CLASS AT 60 Hz					THERMAL CURRENT RATING 1 SECOND RMS AMPS
			B0.1	B0.2	B0.5	B0.9	B1.8	
CTW6-125-T100-100	10:5	T100	0.3	0.3	0.3	0.3	0.6	900*
CTW6-125-T100-150	15:5	T100	0.3	0.3	0.3	0.3	0.6	1700*
CTW6-125-T100-250	25:5	T100	0.3	0.3	0.3	0.3	0.6	2700*
CTW6-125-T100-500	50:5	T100	0.3	0.3	0.3	0.3	0.6	4700*
CTW6-125-T100-750	75:5	T100	0.3	0.3	0.3	0.3	0.6	12900*
CTW6-125-T100-101	100:5	T100	0.3	0.3	0.3	0.3	0.6	12900*
CTW6-125-T100-151	150:5	T100	0.3	0.3	0.3	0.3	0.6	23000*
CTW6-125-T100-201	200:5	T100	0.3	0.3	0.3	0.3	0.6	28200*
CTW6-125-T100-301	300:5	T100	0.3	0.3	0.3	0.3	0.6	48900*
CTW6-125-T100-401	400:5	T100	0.3	0.3	0.3	0.3	0.6	66200*
CTW6-125-T100-601	600:5	T100	0.3	0.3	0.3	0.3	0.6	66200*

* With a burden of B0.2 or greater connected to the secondary.

CTW6-125-T200-100	10:5	T200	0.3	0.3	0.3	0.3	0.3	900**
CTW6-125-T200-150	15:5	T200	0.3	0.3	0.3	0.3	0.3	1700**
CTW6-125-T200-250	25:5	T200	0.3	0.3	0.3	0.3	0.3	2700**
CTW6-125-T200-500	50:5	T200	0.3	0.3	0.3	0.3	0.3	4700**
CTW6-125-T200-750	75:5	T200	0.3	0.3	0.3	0.3	0.3	12900**
CTW6-125-T200-101	100:5	T200	0.3	0.3	0.3	0.3	0.3	12900**
CTW6-125-T200-151	150:5	T200	0.3	0.3	0.3	0.3	0.3	23000**
CTW6-125-T200-201	200:5	T200	0.3	0.3	0.3	0.3	0.3	28200**
CTW6-125-T200-301	300:5	T200	0.3	0.3	0.3	0.3	0.3	48900**
CTW6-125-T200-401	400:5	T200	0.3	0.3	0.3	0.3	0.3	66200**
CTW6-125-T200-601	600:5	T200	0.3	0.3	0.3	0.3	0.3	66200**

** With a burden of B0.5 or greater connected to the secondary.

*** A test card is provided with each unit.

CTW6-125

RECOMMENDED MINIMUM SPACINGS

- A; HV to HV
= 8.50" minimum.
- B; HV to Ground in Air
= 8.50" minimum.
- C; Unit to Unit
= 2.00" minimum.

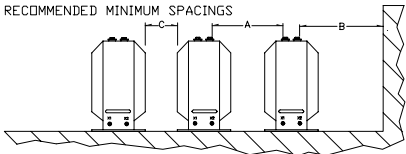

Recommended spacings are for guidance only. User needs to set appropriate values to assure performance for high potential test, impulse test, high humidity, partial discharge, high altitude, and other considerations like configuration.

