

# Exhaust Gas Thermocouples

Conax Buffalo Technologies has qualified a line of exhaust gas and wheel space thermocouples to retrofit various GE frame size gas turbine engines. These sensors are engineered and manufactured specifically to the latest revision of OEM specifications.

Conax Buffalo Technologies exhaust gas sensors incorporate high reliability mineral insulated cable, with Type K wire and MgO insulation hermetically sealed in 316 Stainless Steel. Sensor probes are terminated with a proprietary sealing process.

## Features

- High temperature, oxidation resistant sheath material
- Hermetically sealed dual or single, ungrounded junctions
- Hermetically sealed termination
- Conax Buffalo Technologies quality and customer support

## Benefits

- Higher reliability over OEM equipment
- Cost effective retrofit
- Mates with OEM radiation shields

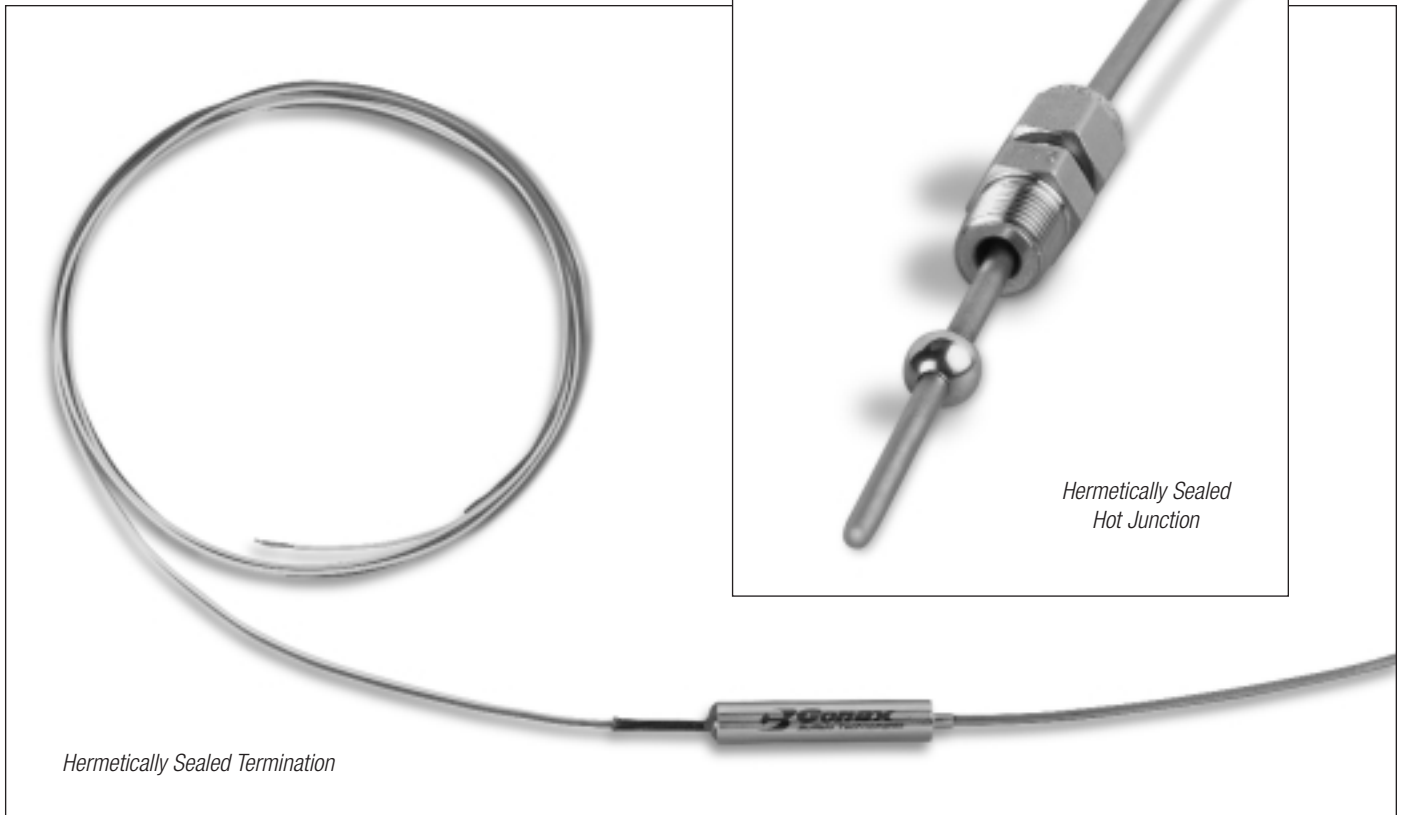

## Dimensional Features

## Exhaust Gas Temperature Sensor Model 351A3488

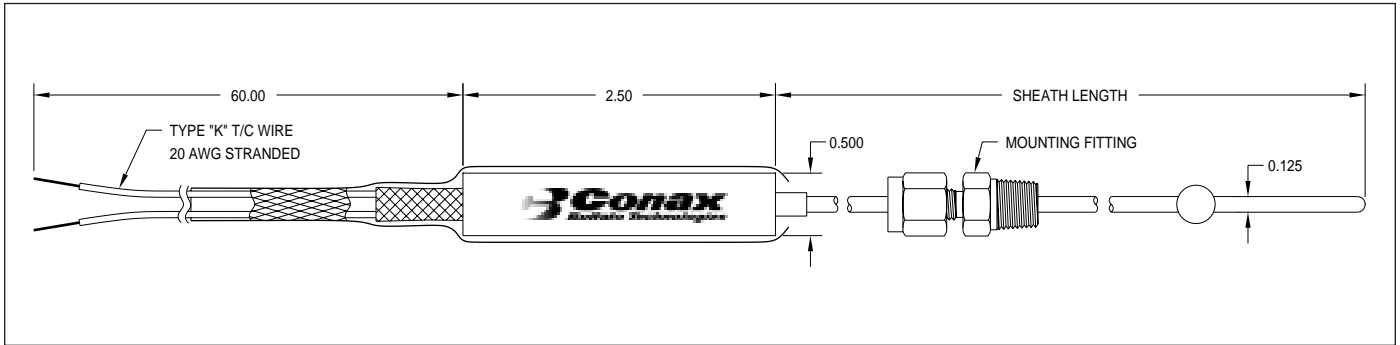

## Specifications

### Calibration:

- Type K, Chromel Alumel®
- $\pm 0.75\%$  accuracy (Standard limits of error)  
OR  $\pm 0.38\%$  accuracy (Special limits of error)
- Meets the requirements of ASTM E585 and ASTM E608

### Insulation Resistance:

- $1 \times 10^9$  ohms @ 50 VDC

### Time Response:

- < 1.3 seconds

### Hermetic Seal:

- $1 \times 10^{-6}$  scc/sec He

### Lead Lengths:

- Customer specified
- Standard length – 5 ft. (1.5m)

## Applications

- Frame 5, 6B/6FA, 7E, 7EA/7FA, 9E/9EC/9FA

## Related Products

- Bearing Sensors
  - Bulletin TP-0200/01
- Bearing Sensor Wire Seals
  - Catalog 5001A
- RTDs / Thermocouples
  - Bulletin 6002
- Fiber Optic Turbine Inlet Temperature Measurement
  - Bulletin 6402

## Represented By:



2300 Walden Avenue  
Buffalo, New York 14225  
FAX: 716-684-7433 • Phone: 716-684-4500  
1-800-223-2389  
e-mail: conaxbuf@conaxbuffalo.com

European Office  
PO Box 91  
BOGNOR REGIS PO22 7JB, England  
FAX: +44 1243 773050 • Phone: +44 1243 784060  
e-mail: cbteurope@compuserve.com

**[www.conaxbuffalo.com](http://www.conaxbuffalo.com) • [www.partsdrawer.com](http://www.partsdrawer.com)**

Chromel-Alumel is a registered trade name of Hoskins Manufacturing • ISO certification refers to Buffalo location.