

Acuvim IIR

Revenue Grade Intelligent Power Meter (Web Accessible)



General Specifications

DESCRIPTION

The Acuvim IIR is a Revenue Grade, Data Logging power meter with a broad range of metering and monitoring capabilities. It is the ideal choice for monitoring and controlling

Acuvim IIR may be used as a data gathering device for an intelligent Power Distribution System or Plant Automation System. All monitored data is available via a digital RS485 communication port running Modbus™ Protocol. Ethernet and Profibus DP communication are also options and with new wireless technologies and protocols currently under development, the applications for the Acuvim IIR meter are limitless.

FEATURES

- 4 MB of on Board Data Logging
- Revenue Grade Verified (ANSI C12.20, Measurement Canada Pending)
- UL, cUL, CE and IP (Environmental) Certified.
- Flexible, Upgradable Module Design (I/O and Communication)
- Multi Communication Ports (Ethernet, RS485, Profibus)
- Advanced LCD Display
- Open MODBUS Protocol
- True-RMS Measuring Parameters
- 4-Quadrant Energy
- Power Quality Analysis
- Over Limit Alarm
- Web Server and Email Sending
- Switch Status Monitoring
- Remote Switch Controlling

Acuvim IIR Meter

CATEGORY		ITEM	PARAMETER
METERING	REAL TIME METERING	Phase Voltage	V1, V2, V3, Vlnavg
		Line Voltage	V12, V23, V31, Vllavg
		Current	I1, I2, I3, In, Iavg
		Power	P1, P2, P3, Psum
		Reactive Power	Q1, Q2, Q3, Qsum
		Apparent Power	S1, S2, S3, Ssum
		Power Factor	PF1, PF2, PF3, PF
		Frequency	F
	ENERGY & DEMAND	Energy	Ep_imp, Ep_exp, Ep_total, Ep_net
		Reactive Energy	Eq_imp, Eq_exp, Eq_total, Eq_net
		Apparent Energy	Es
Demand		Dmd_P, Dmd_Q, Dmd_S	
MONITORING	POWER QUALITY	Voltage Imbalance Factor	U_unbl
		Current Imbalance Factor	I_unbl
		Voltage THD	THD_V1, THD_V2, THD_V3, THD_Vavg
		Current THD	THD_I1, THD_I2, THD_I, THD_Iavg
		Harmonics, Individual	Harmonics 2nd to 31st
		Voltage Crest Factor	Crest Factor
		TIF	THFF
		Current K factor	K Factor
	STATISTICS	MAX with Time Stamp	
		MIN with Time Stamp	
OTHERS	ALARM	Over/Under Limit Alarm	
	COMMUNICATION	RS485 Port	Modbus™ Protocol
	TIME	Real Time Clock	Year, Month, date, Hour, minute, Second
OPTION MODULE	I/O OPTION	Switch Status (DI)	Digital Input (Wet)
		Power Supply for DI	24 Vdc
		Relay Output (RO)	NO, Form A
		Digital Output (DO)	Photo-MOS
		Pulse Output (PO)	By using DO
		Analog Input (AI)	0(4)~20mA, 0(1)~5V
		Analog Output (AO)	0(4)~20mA, 0(1)~5V
	COMMUNICATION	Ethernet	10M/100M, Modbus-TCP, HTTP Webpage, Email
		Profibus-DP	Profibus-DP/V0

I/O Module (Option)

Module Name	Digital Input (DI)	Power Supply For DI (24V)	Digital Output (DO)	Relay Output (RO)	Analog Input (AI)	Analog Output (AO)
AXM-IO1	6	1		2		
AXM-IO2	4		2			2
AXM-IO3	4			2	2	

Communication Module (Option)

Module Name	Spec		
Ethernet	10M/100M self-adaptable, RJ45 Jack HTTP Web page browse	Modbus-TCP/IP Protocol Email sending on time interval or on event	
Profibus	Profibus-DP/V0 Input Byte (typical): 32 byte Profibus slave mode, baud rate self-adaptable up to 12M	Output Byte (typical): 32 Byte	EN50170 vol.2 compliance

APPLICATIONS

- Metering of distribution feeders, transformers, generators, capacitor banks and motors
- Medium and low voltage systems
- Commercial, industrial, utility
- Power quality analysis

FEATURES

Metering

- Voltage V1, V2, V3, Vlnavg, V12, V23, V31, Vllavg
- Current I1, I2, I3, In, Iavg
- Power P1, P2, P3, Psum
- Reactive Power Q1, Q2, Q3, Qsum
- Apparent Power S1, S2, S3, Ssum
- Frequency F
- Power Factor PF1, PF2, PF3, PF
- Energy Ep_imp, Ep_exp, Ep_total, Ep_net
- Reactive Energy Eq_imp, Eq_exp, Eq_total, Eq_net
- Apparent Energy Es
- Demand Dmd_P, Dmd_Q, Dmd_S

Monitoring

- Power Quality
- Voltage Harmonics 2nd to 31st and THD
- Current Harmonics 2nd to 31st and THD
- Voltage Crest Factor
- THFF (TIF)
- Current K Factor
- Voltage Unbalance Factor U_unbl
- Current Unbalance Factor I_unbl
- Max/Min Statistics with Time Stamps

Alarms

Limits can be set for up to 16 indicated parameters and can be set with a specified time interval. If any input of the indicated parameters is over or under its setting limit and persists over the specified time interval, the event will be recorded with time stamps and trigger the Alarm DO output. The 16 indicated parameters can be selected from any of the 44 parameters available.

I/O option module

The E-module® technique was adopted for its flexibility and easy expansion of the I/O function of Acuvim IIR. A maximum of 3 modules can be used for one meter. Digital input, digital output, pulse output, relay output, analog input and analog output are provided by I/O option module.

Communication

RS485, Industry standard Modbus™ protocol
Module Option: Ethernet module, Profibus-DP module
Dual communication ports

Display

Clear and large character LCD Screen display with white back light
Wide environmental temperature endurance
Display Load percentage, 4 quadrants power and load nature

Outline

Small Size 96x96 DIN or 4" ANSI Round

Typical Web Page From Acuvim IIR

The screenshots show the following data:

Max & Min Record

Channel	Maximum	Time Stamp	Minimum	Time Stamp
Volts AN	442.3 V	2006-10-11 17:29:30	0.0 V	2006-10-2 13:43:59
Volts BN	444.1 V	2006-10-11 17:29:32	0.0 V	2006-10-2 13:43:59
Volts CN	444.2 V	2006-10-11 17:29:32	0.0 V	2006-10-2 13:43:59
Volts AB	754.6 V	2006-11-5 11:41:18	0.0 V	2006-10-2 13:43:59
Volts BC	759.7 V	2006-11-5 10:33:30	0.0 V	2006-10-2 13:43:59
Volts CA	760.1 V	2006-11-4 18:35:22	0.0 V	2006-10-2 13:43:59
I A	11.913 A	2006-11-4 17:58:11	0.000 A	2006-10-2 14:14:48
I B	20.736 A	2006-11-5 9:32:47	0.000 A	2006-10-2 14:14:41
I C	11.053 A	2006-11-5 18:12:10	0.000 A	2006-10-2 14:14:47
Watt Total	11.410 kW	2006-11-5 9:15:29	-1.658 kW	2006-11-6 11:13:58
VAR Total	4.326 kVAR	2006-11-5 17:16:00	-3.753 kVAR	2006-11-5 17:51:49
VA Total	11.411 kVA	2006-11-5 9:15:21	0.000 kVA	2006-11-2 13:43:59
Power Factor Total	1.000	2006-10-2 13:22:44	-1.000	2006-11-6 11:41:34

SOE Record

NO	Time Stamp	DI Status
NO1	2006-10-28 15:20:22.603	D1-OFF D2-OFF D3-OFF D4-OFF D5-OFF D6-OFF
NO2	2006-10-28 15:20:43.969	D1-ON D2-ON D3-ON D4-OFF D5-OFF D6-OFF
NO3	2006-10-28 15:20:43.969	D1-ON D2-ON D3-ON D4-OFF D5-OFF D6-OFF
NO4	2006-10-28 15:20:43.969	D1-ON D2-ON D3-ON D4-OFF D5-OFF D6-OFF
NO5	2006-10-28 15:20:49.328	D1-OFF D2-ON D3-OFF D4-OFF D5-OFF D6-OFF
NO6	2006-10-28 15:20:49.328	D1-OFF D2-ON D3-OFF D4-OFF D5-OFF D6-OFF
NO7	2006-10-28 15:20:49.329	D1-OFF D2-ON D3-OFF D4-OFF D5-OFF D6-OFF
NO8	2006-10-28 15:23:57.743	D1-ON D2-ON D3-ON D4-ON D5-OFF D6-OFF
NO9	2006-10-28 15:24:12.649	D1-OFF D2-ON D3-ON D4-OFF D5-OFF D6-OFF
NO10	2006-10-28 15:24:34.345	D1-ON D2-ON D3-ON D4-ON D5-OFF D6-OFF
NO11	2006-10-28 15:24:14.120	D1-OFF D2-ON D3-ON D4-OFF D5-OFF D6-OFF
NO12	2006-10-28 15:24:18.762	D1-ON D2-ON D3-ON D4-ON D5-OFF D6-OFF
NO13	2006-10-28 15:24:23.989	D1-OFF D2-ON D3-ON D4-OFF D5-OFF D6-OFF
NO14	2006-10-28 15:24:29.241	D1-ON D2-ON D3-ON D4-ON D5-OFF D6-OFF
NO15	2006-10-28 15:24:36.536	D1-OFF D2-OFF D3-OFF D4-OFF D5-OFF D6-OFF
NO16	2006-10-28 15:20:19.239	D1-OFF D2-OFF D3-OFF D4-ON D5-ON D6-ON
NO17	2006-10-28 15:20:19.239	D1-OFF D2-OFF D3-OFF D4-ON D5-ON D6-ON
NO18	2006-10-28 15:20:19.239	D1-OFF D2-OFF D3-OFF D4-ON D5-ON D6-ON
NO19	2006-10-28 15:20:22.601	D1-OFF D2-OFF D3-OFF D4-ON D5-OFF D6-ON
NO20	2006-10-28 15:20:22.602	D1-OFF D2-OFF D3-OFF D4-OFF D5-OFF D6-ON

Alarm Record

NO	Time Stamp	Limit ID	Status	Alarm Channel	Value
NO1	2006-11-12 9:41:30.51	1	Out	Frequency	60.00 Hz
NO2	2006-11-6 13:33:59.340	1	In	Frequency	60.53 Hz
NO3	2006-11-6 13:35:26.762	1	Out	Frequency	59.70 Hz
NO4	2006-11-6 9:13:48.837	1	In	Frequency	60.20 Hz
NO5	2006-11-6 9:12:49.48	1	Out	Frequency	59.60 Hz
NO6	2006-11-6 9:20:15.495	1	In	Frequency	60.00 Hz
NO7	2006-11-6 9:21:56.694	1	Out	Frequency	60.00 Hz
NO8	2006-11-6 9:22:36.611	1	In	Frequency	65.34 Hz
NO9	2006-11-6 9:22:49.199	1	Out	Frequency	60.00 Hz
NO10	2006-11-6 9:22:50.622	1	In	Frequency	65.04 Hz
NO11	2006-11-6 9:23:38.567	1	Out	Frequency	59.75 Hz
NO12	2006-11-6 9:28:56.913	1	In	Frequency	60.33 Hz
NO13	2006-11-6 9:29:32.880	1	Out	Frequency	59.46 Hz
NO14	2006-10-31 15:37:46.16	2	Out	Volts AN	0.0 V
NO15	2006-10-31 15:37:46.16	3	Out	I A	0.000 A
NO16	2006-10-31 15:37:46.16	4	Out	I C	0.000 A

Energy & Harmonics

Delivered kWh	12.23 kWh	Total Absolute kWh	12.13 kWh	kWh	14.7 kWh
Received kWh	0.1 kWh <td>Total Net kWh</td> <td>11.9 kWh</td> <td></td> <td></td>	Total Net kWh	11.9 kWh		
Delivered kVARh	2.4 kVARh <td>Total Absolute kVARh</td> <td>5.1 kVARh <td></td> <td></td> </td>	Total Absolute kVARh	5.1 kVARh <td></td> <td></td>		
Received kVARh	2.7 kVARh <td>Total Net kVARh</td> <td>0.9 kVARh</td> <td></td> <td></td>	Total Net kVARh	0.9 kVARh		
THD Volts AN/AB	26.79%	THD I A	18.99%		
THD Volts BN/BC	26.39%	THD I B	19.00%		
THD Volts CN/CA	26.66%	THD I C	18.96%		
THD Volts average	26.61%	THD I Average	18.98%		

Acuvim IIR as Web Server

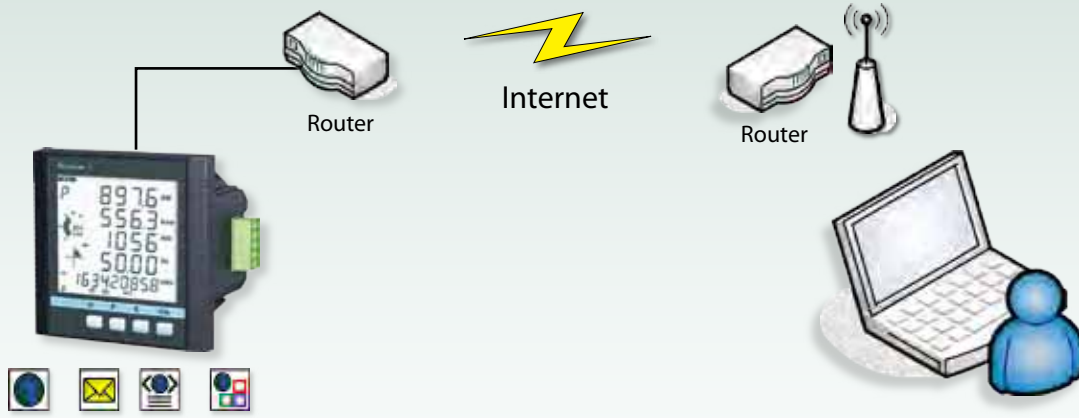

Typical Wiring

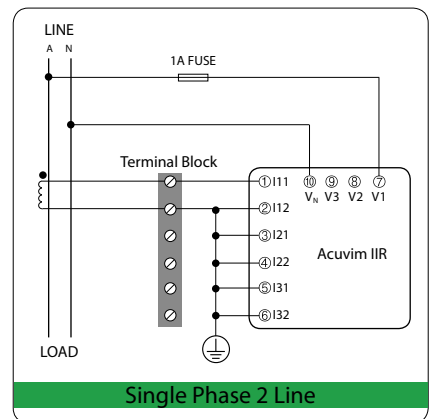
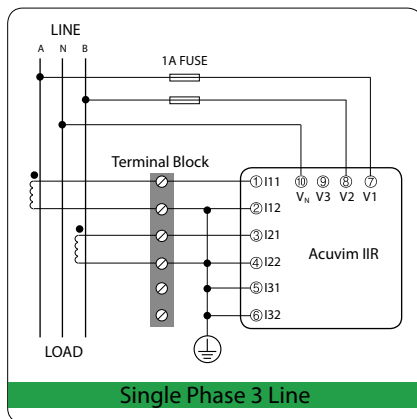
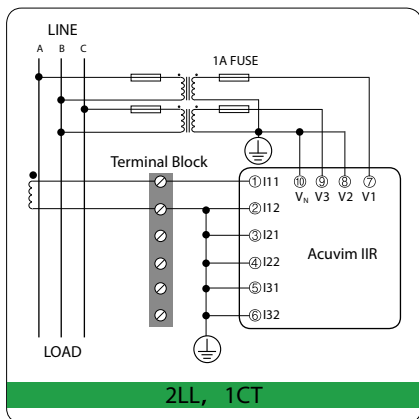
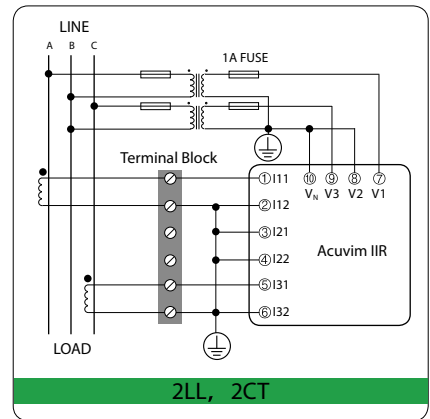
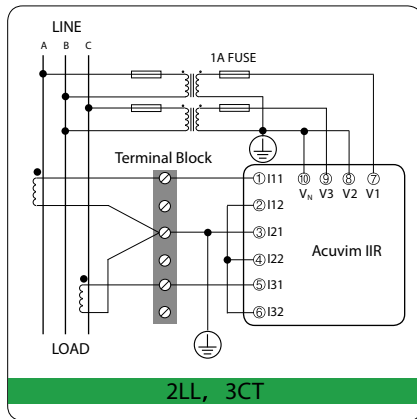
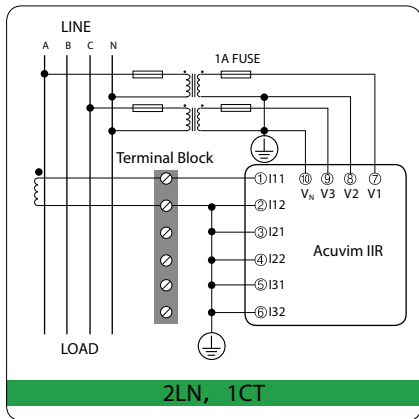
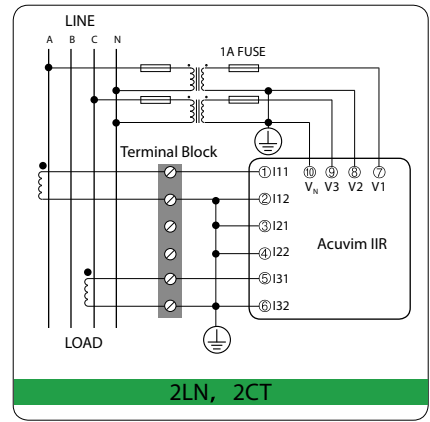
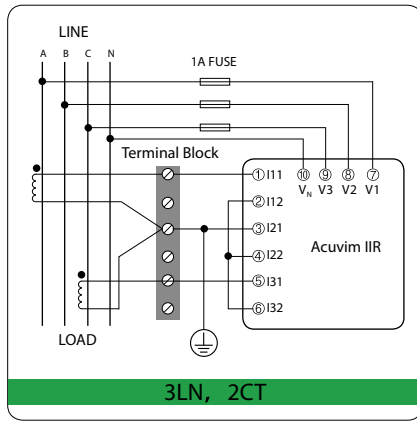
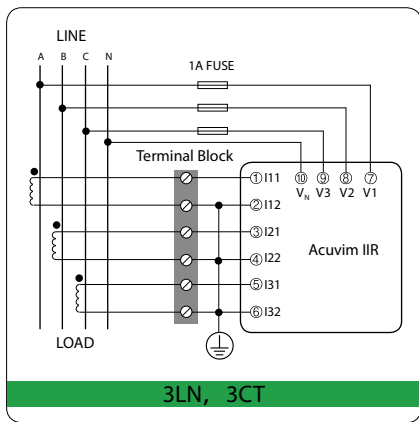

SPECIFICATIONS

METERING				
Parameters	Accuracy	Resolution	Range	
Voltage	0.2%	0.1V	20V~500kV	
Current	0.2%	0.001A	5mA~50000A	
Power	0.5%	1W	-9999MW~9999MW	
Reactive Power	0.5%	1Var	-9999MVar~9999MVar	
Apparent Power	0.5%	1VA	-9999MVA~9999MVA	
Power Demand	0.5%	1W	-9999MW~9999MW	
Reactive Power Demand	0.5%	1Var	-9999MVar~9999MVar	
Apparent Power Demand	0.5%	1VA	-9999MVA~9999MVA	
Power Factor	0.5%	0.001	-1.000~1.000	
Frequency	0.2%	0.01Hz	45.00~65.00Hz	
Energy	Primary	0.5%	0.1kWh	0~99999999.9kWh
	Secondary	0.5%	0.001kWh	0~999999.999kWh
Reactive Energy	Primary	0.5%	0.1kvarh	0~99999999.9kVarh
	Secondary	0.5%	0.001kvarh	0~999999.999kVarh
Apparent Energy	Primary	0.5%	0.1kVAh	0~99999999.9kVAh
	Secondary	0.5%	0.001kVAh	0~999999.999kVAh
Harmonics	2.0%	0.1%	0.0%~100.0%	
Phase Angle	2.0%	0.1°	0.0°~359.9°	
Imbalance Factor	2.0%	0.1%	0.0%~100.0%	
Running Time		0.01h	0~9999999.99h	

COMMUNICATION
RS-485 (Standard) MODBUS RTU Protocol 2-wire connection Up to 38400 baud rate
Ethernet (Optional) 10M/100M BaseT MODBUS TCP/IP Protocol Data Browsing through HTTP Sending e-mail automatically
PROFI-BUS (Optional) PROFIBUS-DP/V0 Protocol Work as PROFIBUS slave, baud rate adaptive, up to 12M Typical input bytes: 32, typical output bytes: 32 PROFIBUS standard according to EN 50170 vol.2

INPUT
Current Inputs (Each Channel) Nominal Current 5 A ac Metering Range 0~10 A ac Withstand 100Arms for 1 second, non-recurring 3250Vac, 50/60Hz for 1 minute Burden 0.05VA (typical) @ 5Arms Pickup Current 0.1% of nominal Accuracy 0.2% full scale Installation Category III (Distribution)
Voltage Inputs (Each Channel) Nominal Full Scale 400Vac L-N, 690Vac L-L Withstand 1500Vac continuous 3250Vac, 50/60Hz for 1 minute Input Impedance 2Mohm per phase Metering Frequency 45Hz~65Hz Pickup Voltage 10Vac Accuracy 0.2% full scale Installation Category III (Distribution)
Energy Accuracy Active (according to IEC 62053-22) class 0.5S Reactive (according to IEC 62053-23) class 2
Harmonic Resolution Metered Value 31st harmonic

CONTROL POWER
Universal AC or DC
AC/DC Control Power Operating Range 100~415Vac, 50/60Hz; 100~300Vdc Burden 5VA typical Frequency 50/60Hz Withstand 3250Vac, 50/60Hz for 1 minute Installation Category III (Distribution)
Low Voltage DC Control Power (Optional) Operating Range 20~60Vdc (±10%) Burden 2.5W typical, 4W maximum

I/O OPTION
Digital Input Input Voltage Range 20~250Vac/dc Input Current (Max) 2mA Start Voltage 15V Stop Voltage 5V Pulse Frequency (Max) 100Hz, 50% Duty Ratio (5ms ON and 5ms OFF) SOE Resolution 2ms
Digital Output (DO) (Photo-MOS) Voltage Range 0~250Vac/dc Load Current 100mA (Max) Output Frequency 25Hz, 50% Duty Ratio (20ms ON, 20ms OFF) Isolation Voltage 2500V
Relay Output (RO) Switching Voltage (Max) 250Vac, 30Vdc Load Current 3A Set Time 10ms (Max) Contact Resistance 100mΩ (Max) Isolation Voltage 2500V Mechanical Life 1.5x10 ⁷
Analog Output (AO) Output Range 0~5V/1~5V, 0~20mA/4~20mA (Optional) Accuracy 0.5% Temperature Drift 50ppm/°C typical Isolation Voltage 500V Open Circuit Voltage 15V
Analog Input (AI) Input Range 0~5V/1~5V, 0~20mA/4~20mA (Optional) Accuracy 0.2% Temperature Drift 50ppm/°C typical Isolation Voltage 500V
Power Supply for DI (24Vdc) Output Voltage 24Vdc Output Current 42mA Load (Max) 21DIs

STANDARD COMPLIANCE	
Product	
USA	UL 61010-1
Canada	cUL 61010-1
Europe	IEC 61010-1
Emission	
Radiated/Conducted	FCC Part 15 Subpart B, Class A
Radiated/Conducted	EN 55011
Harmonic	IEC 61000-3-2
Voltage Fluctuation	IEC 61000-3-3
Radio Interference	EN 50081-2
Immunity	
Electromagnetic Compatibility	IEC 61000-6-2
ESD	IEC 61000-4-2
Radiated, radio-frequency, electromagnetic field	IEC 61000-4-3
Electrical fast transient/burst	IEC 61000-4-4
Surge	IEC 61000-4-5
Conducted disturbances	IEC 61000-4-6
Power frequency magnetic field	IEC 61000-4-8
Voltage dips and interruptions	IEC 61000-4-11
Generic Immunity Standard for Industrial Environment	EN 50082-2

OPERATING ENVIRONMENT	
Operation temperature	- 25°C to 70°C
Storage temperature	- 40°C to 85°C
Relative Humidity	5% to 95% non-condensing
Pollution Degree	2

DIMENSIONS

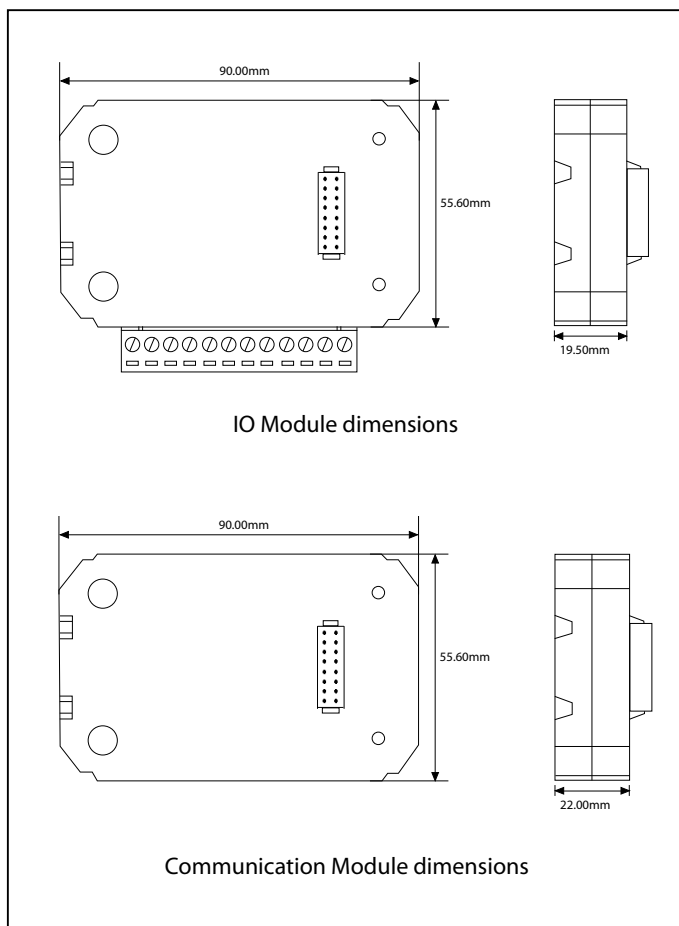
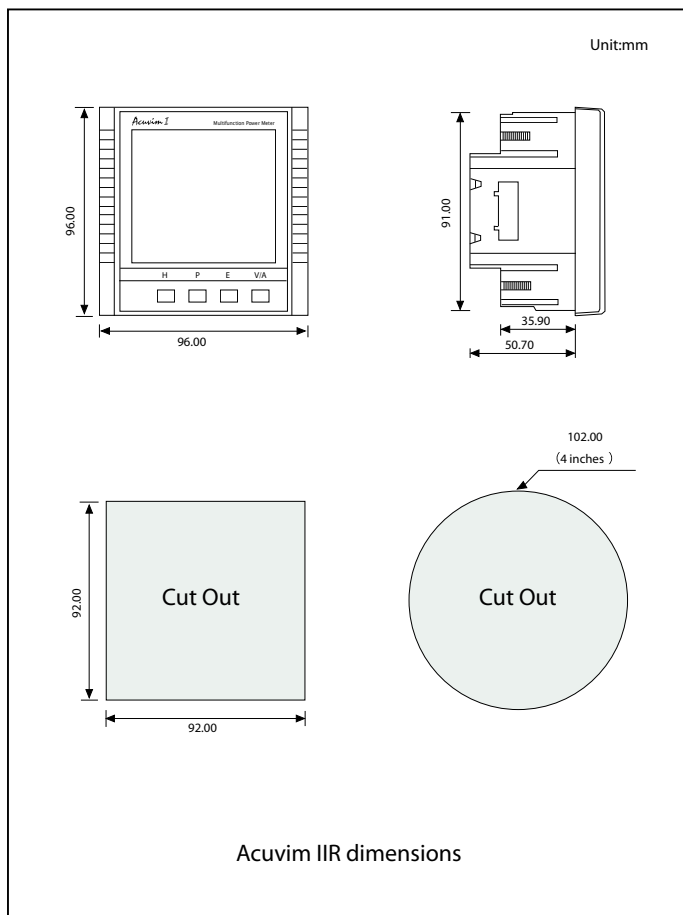

ORDERING INFORMATION

Acuvim IIR

- Note: 1. Current input 5A (1A Option)
 2. Control power supply voltage input
 100~415Vac (±10%), 50-60Hz
 100~300Vdc (±10%)

I/O Option module

- AXM-IO1 (6 DI, 2 RO and Power supply for DI)
- AXM-IO2 (4 DI, 2 DO and 2 AO)
- AXM-IO3 (4 DI, 2 RO and 2 AI)

Communication Option Module

- AXM-NET Ethernet module
- AXM-PROFI Profibus Module

Note:

1. Max 3 Modules for 1 meter
2. Only 1 communication Module for 1 meter
3. Max 2 same type I/O Modules for 1 meter

Electro-Meters

Distributed by Electro-Meters Co. Ltd.

Montreal • Toronto • Calgary

Toll Free: 1-800-617-3413

Web: www.electro-meters.com

Email: sales@electro-meters.com